

**www.e-rara.ch**

## **The Nebraska City Bridge**

**Morison, George S.**

**[Chicago, 1892]**

**ETH-Bibliothek Zürich**

Shelf Mark: Rar 2440

Persistent Link: <https://doi.org/10.3931/e-rara-15604>

---

### **www.e-rara.ch**

Die Plattform e-rara.ch macht die in Schweizer Bibliotheken vorhandenen Drucke online verfügbar. Das Spektrum reicht von Büchern über Karten bis zu illustrierten Materialien - von den Anfängen des Buchdrucks bis ins 20. Jahrhundert.

e-rara.ch provides online access to rare books available in Swiss libraries. The holdings extend from books and maps to illustrated material - from the beginnings of printing to the 20th century.

e-rara.ch met en ligne des reproductions numériques d'imprimés conservés dans les bibliothèques de Suisse. L'éventail va des livres aux documents iconographiques en passant par les cartes - des débuts de l'imprimerie jusqu'au 20e siècle.

e-rara.ch mette a disposizione in rete le edizioni antiche conservate nelle biblioteche svizzere. La collezione comprende libri, carte geografiche e materiale illustrato che risalgono agli inizi della tipografia fino ad arrivare al XX secolo.

---

**Nutzungsbedingungen** Dieses Digitalisat kann kostenfrei heruntergeladen werden. Die Lizenzierungsart und die Nutzungsbedingungen sind individuell zu jedem Dokument in den Titelnformationen angegeben. Für weitere Informationen siehe auch [Link]

**Terms of Use** This digital copy can be downloaded free of charge. The type of licensing and the terms of use are indicated in the title information for each document individually. For further information please refer to the terms of use on [Link]

**Conditions d'utilisation** Ce document numérique peut être téléchargé gratuitement. Son statut juridique et ses conditions d'utilisation sont précisés dans sa notice détaillée. Pour de plus amples informations, voir [Link]

**Condizioni di utilizzo** Questo documento può essere scaricato gratuitamente. Il tipo di licenza e le condizioni di utilizzo sono indicate nella notizia bibliografica del singolo documento. Per ulteriori informazioni vedi anche [Link]

THE NEBRASKA CITY BRIDGE.

RAR 2440 F-KAT S-KAT



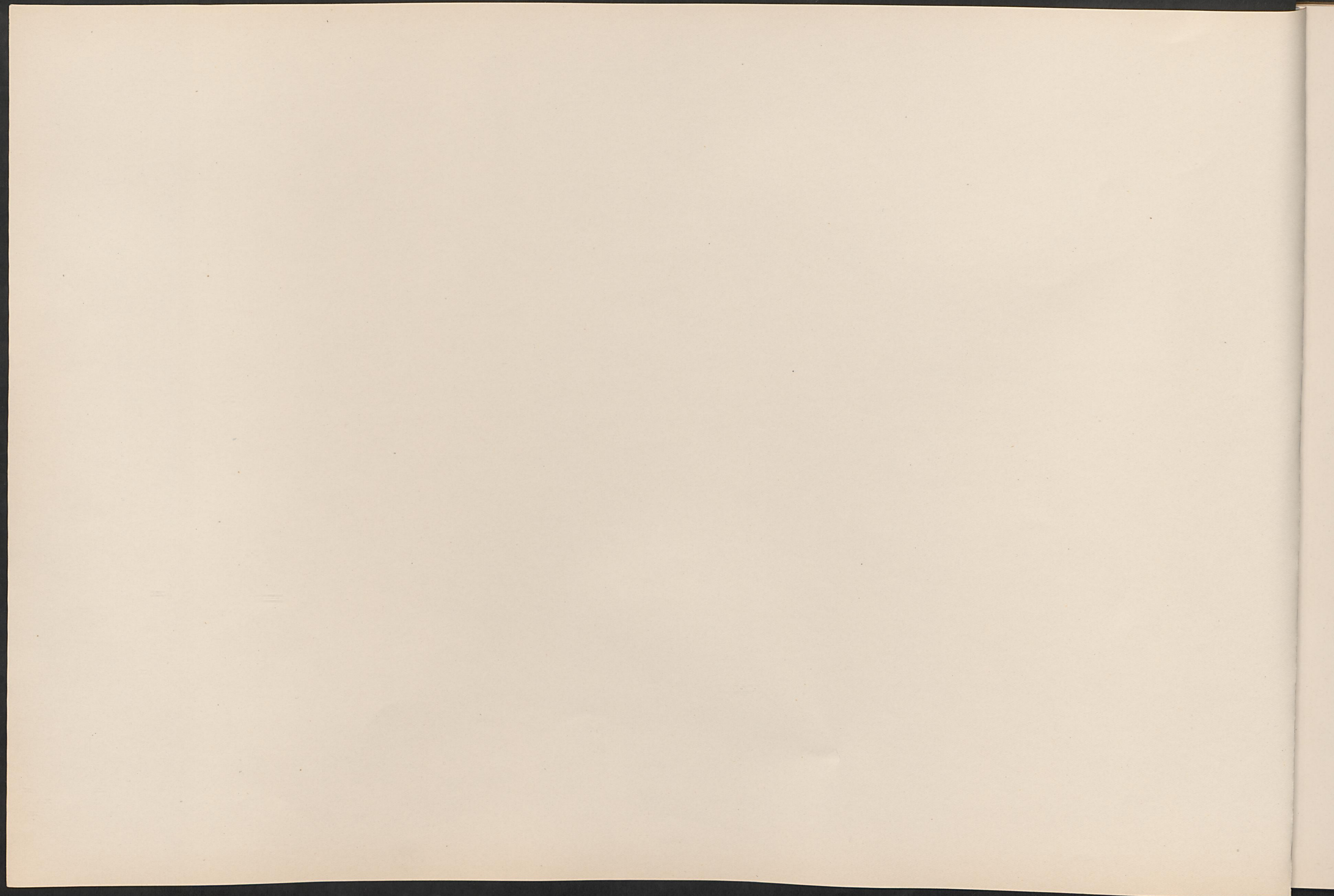





# THE NEBRASKA CITY BRIDGE.

## A REPORT

TO CHARLES E. PERKINS, PRESIDENT CHICAGO, BURLINGTON & QUINCY RAILROAD COMPANY,

BY

GEORGE S. MORISON, CHIEF ENGINEER OF THE NEBRASKA CITY BRIDGE.

### SUBJECTS.

	Page
I. Preliminary Narrative.....	3
II. General Description.....	4
III. Substructure.....	5
IV. Superstructure.....	9
V. Approaches.....	10
VI. Protection Work.....	10
VII. Cost.....	11

### APPENDICES.

A. List of Engineers, Employees and Contractors.....	13
B. Charter and Contract with War Department.....	14
C. Specifications for Masonry.....	16
D. Record of Sinking Caissons.....	17
E. Time, Cost, etc., of Foundations.....	20
F. Specifications for Superstructure.....	23
G. Tests of Full Sized Eye Bars.....	25

### LIST OF PLATES.

1. General Map.
2. General Elevation, Plan, Profile and Alignment.
3. Piers I and IV.
4. Piers II and III.
5. Diagram showing Rate of Progress in Sinking Caissons.
6. Record of Water Stage.
7. 400 ft. Through Span. General Elevation and Plan.
8. " " Panel Point Lo.
9. " " " 1 and 2.
10. " " " 3 and 4.
11. " " " 5 and 6.
12. " " " 7 and Section.
13. " " Strain Sheet.
14. 325 ft. Deck Span. General Elevation and Plan.
15. " " Panel Point Lo.
16. " " " 1 and 2.
17. " " " 3 and 4.
18. " " " 5 and 6.
19. " " Strain Sheet.
20. Floor.

THE NEBRASKA CITY BRIDGE

A REPORT

FOR THE PRESIDENT OF THE CHICAGO, BURLINGTON & QUINCY RAILROAD COMPANY

CHARLES E. PERKINS, Esq.,  
*President Chicago, Burlington & Quincy Railroad Company.*

CHICAGO, July 1st, 1892.

DEAR SIR:—

I submit the following Final Report in relation to the bridge across the Missouri River at Nebraska City, Nebraska.

Yours truly,

GEORGE S. MORISON,  
Chief Engineer Nebraska City Bridge.



## THE NEBRASKA CITY BRIDGE.

## I.

## PRELIMINARY NARRATIVE.

The charter under which the Nebraska City Bridge was constructed was granted by an Act of Congress approved June 4th, 1872. At this time Nebraska City was considered an exceptionally good point for crossing the Missouri River, the channel having followed the Nebraska shore for many years and the river being narrow.

The grant was made to the Nebraska City Bridge Company, a corporation formed under the laws of the State of Nebraska, but it contained an unusual provision, providing for its transfer to any other corporation in the event of its not being used by the Nebraska City Bridge Company. This charter is printed in Appendix B.

In 1872 a location was made by Gen. W. W. Wright, who was Chief Engineer of the Leavenworth and Atchison bridges, and plans were approved by the Secretary of War.

One hundred thousand dollars of ten per cent. bonds were voted for a railroad and wagon bridge by Nebraska City. The bonds were issued to trustees. Nothing further was done at that time. In 1873, there being no bridge in course of construction, \$90,000 of these bonds were burned up in the presence of the Council, Mayor and Trustees, the proceeds of the other ten thousand being used to pay the expenses incurred.

The river was divided by an island known as Nebraska City Island and shown on all the old maps as part of the territory, subsequently the state, of Nebraska. The principal channel was on the east side of the island, but a narrow channel was also open on the west side; the main channel followed the Iowa shore, gradually cutting its way into the bottom land on the east side of the river. As the channel cut into the Iowa shore, the river moved eastward and the accretions formed as part of the island, which was thus greatly enlarged. The river continued narrow below the city, but the track of the K. C., St. J. & C. B. R. R., which in 1870 had been brought to a point nearly opposite, was moved back in 1874 to the location on which it had originally been built in 1868, three years later was moved back again, and in 1884 was moved a third time to its present location. The continued tendency of the bend in the river to move down stream showed that the narrow reach of the river would in a few years entirely disappear.

In 1886 a sudden and important change took place, changing the relative size of the channels east and west of the island, the main river passing down the west side of the island, and leaving only a secondary channel almost dry at low water east of the island. This change of a single season restored the condition of the river to what it had been thirty years before, with the exception, however, that the island was east instead of west of the main channel. The very favorable conditions for bridging the river were restored, but it was evident that unless some artificial means were taken to prevent it, the river would again go through the same manœuvres as before and would cut away the island and sand bar west of where the channel had recently been and resume its late position; and furthermore, that as the material recently deposited was sand and silt, the change would take place rapidly. If anything was to be done with the river it must be done at once.

In the fall of 1886 I visited Nebraska City and on October 22nd, 1886, I placed Mr. Addison Connor there with instructions to make an accurate survey of the river; Mr. Connor continued there till June 2nd, 1887.

As soon as the surveys were sufficiently advanced it became clear to me that the proper method of handling the case was to close what remained of the channel east of the island entirely by building a dike across the same, and to extend this dike to within a thousand feet of the Nebraska shore; the bridge to be located about 1,500 feet below the dike. As the location of the bridge was determined in a considerable degree by the form of the bluffs on the west side of the river, the position of the dike was determined by the location of the bridge, rather than the location of the bridge by the position of the dike. It was evident that even if no bridge was to be built the dike would become necessary if a transfer was to be maintained at this point.

About the first of February, 1887, I received authority from you to begin the construction of the dike. The work was placed in the hands of Mr. B. L. Crosby as Resident Engineer, Mr. Connor continuing in immediate charge.

The line of railroad from Lincoln to Brownville by way of Nebraska City being owned by the Nebraska Railway Company, one of your proprietary corporations, it was thought best to have the bridge built by the Nebraska Railway Company. Through the assistance of Hon. J. Sterling Morton, of Nebraska City, an assignment of the charter was procured from the Nebraska City Bridge Company to the Nebraska Railway Company.

On April 14th, 1887, I submitted the plans of the bridge to the Hon. W. C. Endicott, Secretary of War, for approval. After some little delay this approval was granted, the company being required, however, to raise the bridge two feet higher than had been intended, the result being that the bridge is now 53.33 feet above the Standard High Water as adopted by the Missouri River Commission. On June 27th, 1887, the contract required by the War Department was executed by the Nebraska Railway Company. This contract is printed in Appendix B.

Authority was given for the construction of the bridge immediately upon the approval of the plans. On the 6th of June Mr. B. L. Crosby was instructed as Resident Engineer to make his headquarters at Nebraska City and take charge of the work.

The Steamer John Bertram with a full outfit of pneumatic machinery which had been used on the Rulo Bridge was sent to Nebraska City and arrived July 24th.

The first material for the caissons was received August 7th and the framing of the caisson for Pier I, begun August 13th, marks the beginning of the construction of the Nebraska City Bridge.

On November 3d, 1887, the laying of the corner-stone was celebrated by the people of Nebraska City. The stone laid as a corner-stone is the northeast corner of the fourth course in the abutment (Pier IV). In this stone was placed a copper box containing various documents.

I was myself absent from the country from the middle of November, 1887, to the end of the following April. During my absence the supervision of this work was handled by my partner, Mr. E. L. Cort-hell, who acted as Associate Chief Engineer during the existence of our partnership, from May, 1887, to April, 1889.

The work on the bridge went on continuously without interruption till its completion. The last span was swung on June 8th, 1888, but the East Approach and the tracks on the west side were not entirely complete at that time. The first locomotive crossed the bridge July 27th, 1888, and the tracks were completed on both approaches so that regular trains began using the bridge August 12th, 1888.

The actual time from framing of the first timber to the opening of the bridge to general traffic was one day less than a year.

The completion of the bridge, together with other events, were celebrated by the people of Nebraska City on the 30th day of August, 1888.

In the summer of 1890 it was determined to open the bridge to highway traffic as well as to railroad traffic. The floor of the main bridge was therefore planked, iron fences were put on the two sides and a highway trestle approach built leading south from near the west end of the East Approach trestle. The bridge was opened for highway traffic June 15, 1891.

## II.

## GENERAL DESCRIPTION.

The Nebraska City Bridge is a single-track railroad bridge. It consists of two through spans each 400 feet between centers of end pins, resting on two masonry piers and one masonry abutment, and of one deck span 325 feet long at the east end, resting on one masonry pier and one smaller pier formed of two iron cylinders supported on a caisson. The bridge is 1 132' 4" long from center to center of end pins.

Highway traffic is provided for by planking the railroad floor with two thicknesses of plank and putting substantial iron fences on each side. The highway traffic, therefore, uses the same roadway as the railroad traffic and the bridge is closed to one class of traffic while the other is crossing. On the west side of the river the highway traffic turns to the north on a graded approach immediately on leaving the bridge; on the east side it turns to the south on a trestle built with a five per cent. grade.

The East Approach extends from a connection with the tracks of K. C., St. J. & C. B. R. R. on the east side of the river to the end of the iron work. The West Approach is only 539 feet long from the end of the abutment to a connection with the tracks of the Nebraska Railway in the cut west of the bridge.

During the construction of the bridge and the protection works, a line was built by the K. C., St. J. & C. B. R. R. connecting its branch to East Nebraska City with its main line 4.43 miles north of Nebraska City Junction, thus forming a second line between Nebraska City Junction and the new junction point named Morison on the time

tables. The loop-line is 2.296 miles longer than the direct line and gives an approach to the Nebraska City Bridge from each direction, besides connecting with the protection track leading to the dike above. At the same time the location of the Nebraska Railway was changed for a distance of about a mile east of the station, the new line being carried over the Missouri Pacific Ry., thus avoiding an objectionable grade crossing and connecting with the old line on the base of the bluff about 3 000 feet below the bridge. The bridge approach connects with the main line of the Nebraska Railway as thus reconstructed.

The north half of the K. C., St. J. & C. B. R. R. loop line is built on a line parallel with and 1 500 feet distant from the axis of the bridge. This tangent is continued southwesterly till it reaches the dike, and then following the line of the dike, continues to the bridge line; the track from the connection point to the end of the dike was built by the Nebraska Ry. as a part of the Nebraska City Bridge work. The track on the embankment across the old channel east of the island, which was built solid so as to prevent any flow of water, was constructed by and belongs to the K. C., St. J. & C. B. R. R.

During the construction of the bridge all levels were connected with the benches established by the Missouri River Commission and referred to the St. Louis City Directrix, which is 412.71 feet above mean tide at Biloxi, Miss.

After the bridge was turned over to the Operating Department the track on the portion of the Kansas City, St. Joseph & Council Bluffs Railroad loop running north of the connection with the north branch of the approach track was taken up. I regard this as a very unwise and dangerous proceeding, as it deprived the Railroad Company of its means of repairing the dike. In the summer of 1891 the water broke through the bank across the old east channel. Instructions were subsequently given to repair this, though not until some months after it had occurred. It is of the utmost importance that this track should be maintained.

## III.

## SUBSTRUCTURE.

The substructure consists of one iron cylinder pier, two masonry piers and one abutment. The iron cylinder pier at the east end is designated as Pier I; the two masonry piers are designated as Piers II and III and the abutment as Pier IV. Piers I, II and III are founded on pneumatic caissons of the following dimensions:

Caisson I	38 feet long,	18 feet wide	and 12 feet high.
Caisson II	54 " " 24 " " "	15 " "	
Caisson III	54 " " 24 " " "	15 " "	

The caisson of Pier I is surmounted by a crib work 45 feet high, of rectangular section, built with a side batter of 1 in 24. The caisson for Pier II is surmounted by a crib work 13 feet high and that of Pier III with crib work 15 feet high, both of these cribs having the corners cut off and being built with a side batter of 1 in 24. The caissons and crib work are filled with concrete, that of Pier I being generally made with Milwaukee cement; that of Piers II and III with Portland cement. The rock on which these piers rest is a limestone rock overlaid at Pier II with about 20 inches of shale and five feet of clay, and at Pier III with about 26 inches of shale. The remainder of the material through which the piers were sunk was the fine sand which is the usual alluvial deposit of the Missouri River. The limestone was drilled into and found to be 30 inches thick and to rest on clay or shale.

The caisson for Pier I was built on the sand-bar on the east side of the bridge; the other two caissons were built on false work and lowered by long screws to the bottom of the river.

The foundations were put in by the company's own men under the direction of the Resident Engineer. The masonry was built by contract by the firm of T. Saulpaugh & Co.

A pile bridge was built 50 feet north of the bridge line extending beyond Pier III to serve as a service bridge to handle material for the substructure.

## PIER I.

The excavation of the pit at the site of Pier I was begun Sept. 1st, 1887; the building of the caisson was begun Nov. 14th, 1887, and the concrete filling of this caisson December 8th. Air pressure was put on Dec. 9th. The first sections of iron cylinder were set up Dec. 23rd and the caisson reached the rock at elevation 442.38, Jan. 2nd, 1888. The sealing of the working chamber was begun Jan. 2nd at two P. M., and completed on the following day at 11:30 A. M. air pressure being let off on the following morning. The pier was entirely completed January 30th, 1888.

The cylinders which form the top of this pier are 8½ feet in diameter and 18½ feet high. The shells are of  $\frac{9}{16}$  inch wrought iron plates and extend seven feet below the top of the crib into the concrete. The caps are of cast iron and the two cylinders are connected by a wrought iron lattice frame. The wrought iron shells and the cast iron caps are part of the piers of the old Omaha Bridge and were bought from the Union Pacific Ry. Co. The cross frame is new.

## PIER II.

The first piles were driven for the staging of this pier October 19, 1887. The cutting edge was set up December 21st and the caisson lowered on the bottom Jan. 10th, reaching the bottom at elevation 493.1 in 8.5 feet of water. Air pressure was put on Jan. 11th; the crib with its concrete filling was finished Jan. 24th and the laying of the masonry begun Jan. 29th. The caisson reached the rock at elevation 442.86 Feb. 19th. The rock was cleaned and the sealing of the caisson begun Feb. 20th; the sealing was finished February 22d. The masonry of this pier was finished May 2nd, 1888.

## PIER III.

This was really the first foundation put in. The driving of the piles for the staging was begun Oct. 3rd, 1887, the cutting edge set up October 11th and the erection of the timber begun October 14th. The caisson was lowered to the bottom Nov. 3rd, reaching the bottom at elevation 484.5 in 14.4 feet of water on Nov. 6th, when air pressure was put on. The crib with its concrete filling was finished Nov. 12th and the laying of masonry begun Nov. 14th. The caisson reached the rock at elevation 442.91 Dec. 3rd and the sealing of the working chamber was begun Dec. 4th and completed Dec. 7th, when air pressure was let off. The masonry of this pier was finished Jan. 27th, 1888.

## PIER IV.

The west abutment, designated in the records as Pier IV, is founded at elevation 516.05 on a layer of limestone 1.78 feet thick, which occurs in a formation of hard blue shale.

The foundations of the wing walls were stepped back on top of thin layers of stone that occurred in the shale; the excavations were leveled up with concrete on which the masonry was started.

The excavation of the pit for this abutment was begun September 2nd, 1887. The first stone was set Oct. 27th. The corner stone, at the northeast corner of the fourth course, was laid with ceremonies Nov. 3rd and the masonry of the abutment was completed December 26th.

The full details of the four piers are given on Plates 3 and 4. The rate of progress in sinking is illustrated graphically on Plate 5. Full records of the progress in detail in sinking these foundations were kept and are given in Appendix D. The detail cost is given in Appendix E.

## THE NEBRASKA CITY BRIDGE.

The cost of the three pneumatic foundations is shown in detail in the following table:

	Cost, excluding Freight Charges.	Freight Charges.	COST, INCLUDING FREIGHT CHARGES.		
<b>FOUNDATION PIER I.</b>					
CAISSON—					
Material.....	\$ 1 550.39	\$ 278.34	\$1 828.73		
Labor.....	1 525.87	....	1 525.87		
			\$3 354.60		
CONCRETE FILLING—					
Material.....	1 337.61	394.74	1 732.35		
Labor.....	491.28	....	491.28		
			2 223.63		
CRIB—					
Material.....	2 082.43	461.43	2 543.86		\$ 5 578.23
Labor.....	931.28	....	931.28		
			3 475.14		
CONCRETE FILLING—					
Material.....	1 535.16	987.84	2 523.00		
Labor.....	1 185.43	....	1 185.43		
			3 698.43		
CYLINDERS—					
Material.....	971.12	3.00	974.12		7 173.57
Labor.....	431.19	....	431.19		
			1 405.31		
CONCRETE FILLING—					
Material.....	255.00	138.90	393.90		
Labor.....	285.78	....	285.78		
			679.68		
CUTTING EDGE, AIR LOCK, SHAFTS, ETC.....	2 239.54	42.72	2 282.26		2 084.99
					2 282.26
SINKING—					
Material.....	611.57	408.80	1 020.37		
Labor.....	3 844.53	....	3 844.53		
			4 864.90		
DIGGING PIT AND RE-FILLING AROUND CYLINDERS.....	532.57	....	532.57		532.57
WORK TRAIN SERVICE.....	802.76	....	802.76		802.76
	20 603.51	2 715.77			\$23 319.28
<b>FOUNDATION PIER II.</b>					
CAISSON—					
Material.....	2 759.71	377.29	3 137.00		
Labor.....	2 294.66	....	2 294.66		
			5 431.66		
FALSE WORK—					
Material.....	669.31	92.67	761.98		
Labor.....	592.20	....	592.20		
			1 354.18		
CONCRETE FILLING—					
Material.....	3 434.76	1 027.50	4 462.26		
Labor.....	1 330.18	....	1 330.18		
			5 792.44		
CRIB—					
Material.....	836.50	177.60	1 014.10		12 578.28
Labor.....	773.84	....	773.84		
			1 787.94		
CONCRETE FILLING—					
Material.....	1 555.57	467.53	2 023.10		
Labor.....	897.35	....	897.35		
			2 920.45		
			4 708.39		
<b>FOUNDATION PIER II.—Continued.</b>					
CUTTING EDGE, AIR LOCK, SHAFT, ETC.....	\$ 1 932.48	\$ 40.36	\$1 972.84		\$ 1 972.84
SINKING—					
Material.....	725.68	441.39	1 167.07		
Labor.....	5 835.47	....	5 835.47		
			7 002.54		
WORK TRAIN SERVICE.....	823.16	....	823.16		823.16
	24 460.87	2 624.34			\$27 085.21
<b>FOUNDATION PIER III.</b>					
CAISSON—					
Material.....	2 788.90	446.81	3 235.71		
Labor.....	2 741.29	....	2 741.29		
			\$5 977.00		
FALSE WORK—					
Material.....	714.17	95.36	809.53		
Labor.....	699.93	....	699.93		
			1 509.46		
CONCRETE FILLING—					
Material.....	3 563.35	935.95	4 499.30		
Labor.....	1 142.04	....	1 142.04		
			5 641.34		
CRIB—					
Material.....	1 055.38	201.55	1 256.93		13 127.80
Labor.....	773.90	....	773.90		
			2 030.83		
CONCRETE FILLING—					
Material.....	1 991.71	539.91	2 531.62		
Labor.....	821.14	....	821.14		
			3 352.76		
CUTTING EDGE, AIR LOCK, SHAFT, ETC.....	1 892.95	32.02	1 924.97		5 383.59
					1 924.97
SINKING—					
Material.....	772.68	385.82	1 158.50		
Labor.....	4 711.56	....	4 711.56		
			5 870.06		
WORK TRAIN SERVICE.....	1 205.55	....	1 205.55		1 205.55
	24 874.55	2 637.42			27 511.97
<b>PIER IV. (ABUTMENT.)</b>					
EXCAVATION—					
Material.....	61.06	.20	61.26		
Labor.....	1 380.78	....	1 380.78		
			1 442.04		
CONCRETE—					
Material.....	376.04	175.91	551.95		
Labor.....	280.84	....	280.84		
			832.79		
BACK FILLING WITH CINDERS.....	862.22	....	862.22		2 274.83
			862.22		862.22
	2 960.94	176.11			3 137.05
<b>GRAND TOTAL COST OF FOUR FOUNDATIONS.....</b>	<b>\$72 899.87</b>	<b>\$8 153.64</b>			<b>\$81 053.51</b>

# THE NEBRASKA CITY BRIDGE.

A large part of the stone used for the masonry is limestone from Mankato, Minnesota; but the entire dimension work, wherever exposed to frost, is of granite quarried near Morton, Minnesota. The granite begins at the following elevations in the several piers:

Piers.	Up-Stream Ends.	Balance of Pier.
II.	478.54	486.69
III.	480.56	488.73
IV.	525.50	552.96

The specifications for the masonry are given in Appendix C. The cost of the masonry in detail is shown in the following table:

	PIER II.		PIER III.		ABUTMENT. PIER IV.	
	cu. yds.	\$	cu. yds.	\$	cu. yds.	\$
Granite Masonry Laid.....@ \$25.90	708.6	\$18 352.74	716.2	\$18 549.58		
Limestone " ".....@ 19.70	621.4	12 241.58	591.8	11 658.46		
		\$30 594.32		\$30 208.04		
Granite " ".....@ 24.40					359.4	\$ 8 769.36
Limestone " ".....@ 18.20					619.	11 265.80
						\$20 035.16
Allowance for Courses thrown out—Granite.....@ 20.40			17.86	364.34		
Less amount received from sale of above.....				210.00		
				154.34		
Limestone.....@ 14.20			7.76	110.19		
Freight charges on Granite.....		2 157.91		1 846.69		948.44
" " " Limestone.....		1 336.65		1 203.53		1 870.12
		3 494.56		3 050.22		2 818.56
Drain Tile for Weepers.....						8.21
Freight on Tile.....						1.13
						9.34
Work Train service.....		1 245.77		1 358.42		
Portland Cement.....@ 2.78	661	1 837.58	521	1 448.38	390	1 084.20
Freight charges on Cement.....		364.08		286.97		222.39
Labor handling Cement.....		25.04		19.40		19.90
		2 226.70		1 754.75		1 326.49
Total.....		\$37 561.35		\$36 635.96		\$24 189.55
Cost per Yard of Masonry.....		28.24		28.01		24.72
Average Cost per Yard of Masonry.....						26.99

## THE NEBRASKA CITY BRIDGE.

The cost of the four Piers was as follows:

	COST EXCLUDING FREIGHT.			FREIGHT CHARGES.			COST INCLUDING FREIGHT.			Gross Volume.	Cost per Cubic ft.	Cubic feet sunk. Area of Base x feet sunk.	Cost per Cubic ft.	Vertical feet sunk below standard low water.	Cost per Vertical foot.
										cu. ft.	cts.	cu. ft.	cts.	feet.	
<b>FOUNDATION PIER I.</b>															
Caisson and Filling, including Cutting Edge, etc.	\$7 144.69			\$ 715.80			\$7 860.49			8 208	95.77				
Crib and Filling.....	5 724.30			1 449.27			7 173.57			25 252	28.4				
Cylinders and Filling.....	1 943.09			141.90			2 084.99								
Sinking Caisson.....	4 456.10			408.80			4 864.90					38 268	12.7	55.26	88.04
Digging Pit and Refilling around Cylinders.....	532.57						532.57								
Work Train Service.....	802.76						802.76								
			\$20 603.51			\$2 715.77			\$23 319.28						
<b>FOUNDATION PIER II.</b>															
Caisson and Filling, including False Work, etc.	13 013.30			1 537.82			14 551.12			19 940	72.97				
Crib and Filling.....	4 063.26			645.13			4 708.39			14 816	31.78				
Sinking Caisson.....	6 561.15			441.39			7 002.54					71 689	9.8	54.78	127.83
Work Train Service.....	823.16						823.16								
			24 460.87			2 624.34			27 085.21						
<b>FOUNDATION PIER III.</b>															
Caisson and Filling, including False Work, etc.	13 542.63			1 510.14			15 052.77			19 940	75.49				
Crib and Filling.....	4 642.13			741.46			5 383.59			16 932	31.8				
Sinking Caisson.....	5 484.24			385.82			5 870.06					71 624	8.2	54.73	107.25
Work Train Service.....	1 205.55						1 205.55								
			24 874.55			2 637.42			27 511.97						
<b>FOUNDATION PIER IV. (Abutment.)</b>															
Excavation and Concrete.....	2 098.72			176.11			2 274.83								
Backfilling with Cinders.....	862.22						862.22								
			2 960.94			176.11			3 137.05						
<b>TOTAL COST OF FOUNDATIONS.....</b>			<b>\$72 899.87</b>			<b>\$ 8 153.64</b>			<b>\$81 053.51</b>					Mean 10.2	Mean 104.37
<b>MASONRY, PIER II.....</b>															
	33 702.71			3 858.64			37 561.35								
<b>MASONRY, PIER III.....</b>															
	33 298.77			3 337.19			36 635.96								
<b>MASONRY, PIER IV. (Abutment).....</b>															
	21 147.47			3 042.08			24 189.55								
<b>TOTAL COST OF MASONRY.....</b>			<b>88 148.95</b>			<b>10 237.91</b>			<b>98 386.86</b>						
<b>GRAND TOTAL OF FOUR PIERS.....</b>			<b>\$161 048.82</b>			<b>\$18 391.55</b>			<b>\$179 440.37</b>						

The amount of masonry and concrete in the several Piers and the amount of cement used is given in the following table :

	Masonry Cu. Yards.	Concrete Cu. yards.	Total Cu. yards.	Cement, Bbls.		Total Cement, Bbls.
				Masonry.	Concrete.	
Pier I.....		943.29	9 43.29		2 050	2 050
Pier II.....	1 330.00	931.29	2 261.29	661	1 585	2 246
Pier III.....	1 308.00	960.39	2 268.39	521	1 803	2 324
Pier IV (Abutment).....	978.40	62.02	1 040.42	390	108	498
<b>Total.....</b>	<b>3 616.40</b>	<b>2 896.99</b>	<b>6 513.39</b>	<b>1 572</b>	<b>5 546</b>	<b>7 118</b>

Of the cement used 1650 bbls. in Pier I were Milwaukee cement. All the other was Portland cement.

IV.

SUPERSTRUCTURE.

The superstructure consists of two through spans and one deck span. Each through span is 400 feet long between centers of end pins, and 50 ft. deep, divided into 15 panels of 26 ft. 8 in. each, the trusses being placed 22 feet between centers. The deck span is 325 ft. long and 37 ft. deep, divided into 13 panels of 25 ft. each, the trusses being placed 20 ft. between centers. Expansion is provided on Piers I, II and IV.

The entire superstructure, except a few small details, is of steel.

The trusses are proportioned to carry a moving load of 3000 lbs. per lin. foot, but in calculating the effects of a moving load, the portion of any strain in excess of that which would have been produced by a uniform load of equal amount was taken on a basis of 5000 lbs. per foot. The top lateral system is proportioned to resist a wind pressure of 300 lbs. per lin. foot and the bottom lateral system 500 lbs. per lin. foot. The strains are given on Plates 13 and 19.

The floor system was designed for an uniform load of 6000 lbs. per lin. foot.

The compression strain in the top chord is limited to 14000 lbs. per square inch of balanced section.

The tensile strain in the bottom chord is limited to 13000 lbs. per square inch and that in the web members is somewhat lower.

The weights of iron and steel in the through spans are as follows :

	Two spans. lbs.	Average of two spans. lbs.
Steel.....	2 167 680	1 083 840
Wrought iron.....	11 370	5 865
Cast iron.....	43 550	21 275
Total.....	2 221 600	1 110 800

The weights of iron and steel in the deck span are as follows :

Steel.....	740 346 lbs.
Wrought iron.....	1 936 "
Cast iron.....	13 206 "
Total.....	755 488 "

The specifications under which the superstructure was manufactured are given in Appendix F.

The dates on which the several trusses were erected are shown in the following table :

	First iron placed.	Span swung.
Deck span I- II.....	June 4th, 1888.	June 8th, 1888.
East Through span II-III.....	May 22d, 1888.	May 25th, 1888.
West Through span III-IV.....	Feb. 15th, 1888.	Feb. 19th, 1888.

The timber floor, which was designed to carry a railroad track only, was put on by the company's men, working under the direction of the Resident Engineer. The painting was done in the same way.

The timber floor was subsequently altered to a highway floor under the direction of Mr. E. P. Butts, then Resident Engineer, Burlington

Bridge, in the fall of 1890. The plans of this highway floor are given on Plate 20.

The total cost of the superstructure is given in the following table :

THROUGH SPANS.			
Iron, Steel and Ornamental Work.....	\$97 676.21		
Freight Charges on same from Chicago.....	3 048 26		
Erection.....		\$100 724.47	
Cement, Iron borings, etc.....		20 359.66	
Freight on above.....		12.98	
		1.83	
			\$121 098.94
DECK SPAN.			
Iron and Steel.....	33 907.60		
Freight charges on same from Chicago.....	994.15		
Erection.....		34 901.75	
Cement, iron borings, etc.....		7 040.84	
Freight on same.....		6.50	
Work-train service.....		.91	
		46.93	
			41 996.93
RAILROAD FLOOR.			
Material.....		4 403.09	
Freight.....		216.36	
Labor.....		1 621.22	
Work-train service.....		16.00	
			6 256.67
HIGHWAY FLOOR.			
Material.....		5 603.72	
Freight.....		134.88	
Labor.....		3 720.35	
			9 458.95
PAINTING.			
Material.....		847.68	
Freight.....		13.08	
Labor.....		3 633.32	
			4 494.08
TOTAL SUPERSTRUCTURE.....			\$183 305.57

## V.

## APPROACHES.

The East Approach is 5 587 feet long from the connection with the K. C., St. J. & C. B. R. R. loop line to the east end of the iron work. This approach includes a Y track 1 687 feet long, also connecting with the loop line, so that the total length of track in the approach is 7 274 feet. The 3 000 feet next to the bridge was built originally as a timber trestle, the east 1 000 feet of which was built of cottonwood with pine stringers and pine ties, and the remainder entirely of pine. On the completion of the bridge, earth was hauled from the west side of the river, the cottonwood trestle filled entirely and the pine trestle filled to average elevation 513, this being about eight feet above the average ground level. The graded embankment was widened at the same time.

The amount of earth in the East Approach is as follows:

Borrowed on east side.....	33 648	cubic yds.
Steam shovel work hauled from cut...	17 246	" "
Team work hauled from cut.....	61 012	" "
Total .....	111 906	" "

Both the steam shovel and team work were hauled across the bridge with trains, the shovel and teams being used only to load the cars.

The West Approach is 539 feet long and is entirely in a cut, the total amount of material excavated on this approach being 15 472 yards.

The contract for grading the East Approach was let to Andrew Sheridan, of St. Joseph, Mo.

The earth carried across the bridge was taken from the cut on the revised line of the Nebraska Railway, the cut being enlarged for this purpose. The steam shovel work was done under contract by Dorwin & Lundquist. The team work was done by Andrew Sheridan.

## VI.

## PROTECTION WORK.

The protection work, which would more properly be called rectification work, consists of a dike on the east side of the river, this dike being the western end of an embankment extending across the sand-bar and across the old channel between the island and the Iowa shore. The embankment and track was built by the Kansas City, St. Joseph and Council Bluffs Railroad as a part of its loop line, and its cost does not appear as a portion of the cost of the Nebraska City Bridge. This embankment, as well as the finished portion of the dike, were finished at elevation 510, or about one foot higher than the high-water of 1881 at the Nebraska City government gauge.

The position of the dike is shown on Plate 1. The foundation of this dike was a woven willow mattress 125 feet wide of which 100 feet is outside of track center and 25 feet inside. The mattress was woven in position on the sand-bar, wired around the selvage edges, and loaded with rubble stone. When built no portion of it reached the water. After the foundation mattress had been woven and weighted the track was laid 25 feet from the inside edge and brought up to grade with rubble stone. After the completion of the mattress work the river cut into the bank and let the mattress down; as this cutting continued the work was reinforced by throwing in riprap, the mattress serving as a foundation for this riprap protection.

There were used in this dike 1 850 cords of brush, 2 283 lbs. of wire and 4 790 tons of rock.

In the subsequent riprapping, after the completion of the dike and when the river had cut back, everything was put in from trains. There were used 13 615 tons of rock, 2 386 cords of brush and 5 155 lbs. of wire.

The total cost of the dike work was \$54 180.91.

In 1889 the continuation of the protection work was taken in hand by the United States Government under the management of the Missouri River Commission and extended from the end of the dike for a distance of about 4 000 feet up stream along the east shore.

The work of the Government should not be allowed to relieve the Operating Department from the maintenance of the dike and the embankment across the old east channel.

# THE NEBRASKA CITY BRIDGE.

## VII. COST.

The cost of the bridge is shown in the following table :

	Cost, exclusive of Freight Charges.		Freight Charges.		Cost, including Freight Charges.	
Foundation Pier I.....	\$ 20 603.51		\$2 715.77		\$23 319.28	
Foundation Pier II.....	24 460.87		2 624.34		27 085.21	
Foundation Pier III.....	24 874.55		2 637.42		27 511.99	
Foundation Pier IV.....	2 960.94		176.11		3 137.05	
Total Foundations.....		\$72 899.87		\$ 8 153.64		\$81 053.51
Masonry Pier II.....	33 702.71		3 858.64		37 561.35	
Masonry Pier III.....	33 298.77		3 337.19		36 635.96	
Masonry Pier IV.....	21 147.47		3 042.08		24 189.55	
Total Masonry.....		88 148.95		10 237.91		98 386.86
Total Substructure.....		\$161 048.82		\$18 391.55		\$179 440.37
Through Spans.....	118 048.85		3 050.09		121 098.94	
Deck Spans.....	41 001.87		995.06		41 996.93	
Railroad Floor.....	6 040.31		216.36		6 256.67	
Highway Floor.....	9 324.07		134.88		9 458.95	
Painting.....	4 481.00		13.08		4 494.08	
Total Superstructure.....		178 896.10		4 409.47		183 305.57
East Railroad Approach, Grading.....	33 346.35				33 346.35	
East Railroad Approach, Trestle.....	36 058.11		2 956.65		39 014.76	
East Highway Approach.....	8 625.23		58.58		8 683.81	
West Railroad Approach, Grading.....	3 403.83				3 403.83	
West Highway Approach.....	203.66				203.66	
Permanent Track.....	12 002.20		546.01		12 548.21	
Total Approaches.....		93 639.38		3 561.24		97 200.62
Dike.....		39 232.33		14 958.58		54 180.91
Tools and Machinery.....	8 846.19		106.00		8 952.19	
Service Tracks.....	13 757.29		437.88		14 195.17	
Buildings.....	2 098.87		27.42		2 126.29	
Watching.....	2 917.84				2 917.84	
Engineering Salaries.....	29 802.91				29 802.91	
Engineering and Office Expenses.....	3 230.42				3 230.42	
Total Engineering.....		33 033.33		571.30		33 604.63
Land Damages.....	1 136.77				1 136.77	
Preliminary Expenses and Charter.....	6 301.81				6 301.81	
					7 438.58	
Total Cost.....		\$540 898.73		\$41 892.14		\$582 790.87

The item of freight includes freight on the C. B. & Q. system only. In comparing the cost of this bridge with that of other structures, the cost without freight forms the most correct basis for comparison.

This table may be condensed into the following :

	Cost exclusive of Freight Charges.	Freight Charges.	Cost including Freight Charges.
Substructure.....	\$161 048.82	\$18 391.55	\$179 440.37
Superstructure.....	178 896.10	4 409.47	183 305.57
Total Bridge Proper.....	339 944.92	22 801.02	362 745.94
Approaches.....	93 639.38	3 561.24	97 200.62
Dike.....	39 232.33	14 958.58	54 180.91
Tools, Service Tracks, etc.....	27 620.19	571.30	28 191.49
Engineering, etc.....	33 033.33		33 033.33
Land Damages, Preliminary Expenses and Charter.....	7 438.58		7 438.58
Total Cost.....	\$540 898.73	\$41 892.14	\$582 790.87

The cost of the highway accommodations is included in the above. It was as follows :

	Cost exclusive of Freight Charges.	Freight Charges.	Cost including Freight Charges.
Highway Floor.....	\$9 324.07	\$134.88	\$9 458.95
East Highway Approach.....	8 625.23	58.58	8 683.81
West Highway Approach.....	203.66	.....	203.66
Total.....	\$18 152.96	\$193.46	\$18 346.42

MEMORANDUM FOR THE RECORD

DATE

BY

[Faint, illegible text in the main body of the memorandum, appearing to be a list or series of entries.]

## APPENDIX A.

## LIST OF ENGINEERS, EMPLOYEES AND CONTRACTORS.

## ENGINEERS AND COMPANY'S EMPLOYEES.

NAME AND OCCUPATION.	TIME OF SERVICE.
GEORGE S. MORISON, Chief Engineer.	
E. L. CORTHELL, Associate Chief Engineer.	
B. L. CROSBY, Resident Engineer.....	Feb. 7, 1887, to Oct. 31, 1889
ADDISON CONNOR, Assistant Engineer.....	Feb. 1, 1887, to June 2, 1887
EDWIN DURYEA, " " .....	May 1, 1887, to June 16, 1887
M. A. WALDO, " " .....	June 16, 1887, to Oct. 23, 1888
W. S. MACDONALD, " " .....	Nov. 1, 1888, to Feb. 25, 1889
L. V. RICE, " " .....	Oct. 19, 1887, to July 6, 1889
A. J. HIMES, " " .....	June 24, 1887, to July 9, 1888
GEO. R. FERRALL, Rodman.....	July 1, 1887, to Nov. 6, 1888
H. B. ELLETT, Rodman and Inspector.....	Nov. 22, 1887, to April 9, 1889
J. L. MENDENHALL, Clerk.....	July 25, 1887, to Oct. 31, 1889
R. F. THAYER, Timekeeper.....	Aug. 13, 1887, to May 15, 1888
F. H. CRAFTS, Inspector at Quarries.....	Sept. 1, 1887, to Nov. 4, 1887
H. W. PARKHURST, " " .....	Nov. 1, 1887, to Dec. 10, 1887
Z. W. CRAIG, " " .....	Dec. 10, 1887, to May 31, 1888
PAUL WILLIS, Inspector of Superstructure.....	Sept. 20, 1887, to June 1, 1888
R. W. HILDRETH, " " .....	Sept. 22, 1887, to July 3, 1888
R. MODJESKI, " " .....	Nov. 26, 1887, to May 8, 1888
W. A. NETTLETON, " " .....	Jan. 15, 1888, to June 5, 1888
P. H. AYLWARD, Foreman of Pressure Work....	Sept. 1, 1887, to Feb. 23, 1888
CHARLES CONNOR, Master Mechanic.....	July 24, 1887, to July 31, 1888
J. E. GRIFFIN, Foreman of Carpenters.....	Aug. 9, 1887, to July 31, 1888

## CONTRACTORS.

NAME.	NATURE OF WORK.
T. SAULPAUGH & Co.....	Masonry.
CHARLES STEARS.....	Foreman of Masons.
O. W. DAVIS.....	Foreman of Stonecutters.
UNION BRIDGE Co.....	Superstructure.
BAIRD BROS.....	Erection.
GEORGE BUCHAN.....	Superintendent.
ANDREW SHERIDAN.....	Earthwork, Riprap, Stone and Mattress Brush.
DORWIN & LUNDQUIST.....	Earthwork.
FRANK I. MARSH.....	Mattress Brush.

## APPENDIX B.

## ACT OF CONGRESS AUTHORIZING CONSTRUCTION OF NEBRASKA CITY BRIDGE AND CONTRACT WITH WAR DEPARTMENT.

## ACT OF CONGRESS.

AN ACT AUTHORIZING THE CONSTRUCTION OF A BRIDGE ACROSS THE MISSOURI RIVER OPPOSITE TO OR WITHIN THE CORPORATE LIMITS OF NEBRASKA CITY, NEBRASKA.

*Be it enacted by the Senate and House of Representatives of the United States of America in Congress assembled,* That it shall be lawful for the Nebraska City Bridge Company, a corporation having authority from the State of Nebraska and from the State of Iowa, to build a railroad, transit, and wagon bridge across the Missouri River, opposite to or in the immediate vicinity of Nebraska City, in the county of Otoe, and State of Nebraska; and that when constructed, all trains of all railroads terminating at the Missouri River at or near the location of said bridge shall be allowed to cross said bridge, for a reasonable compensation, to be paid to the owners thereof; and that all other property, goods, passengers, teams, and other modes of transit shall be allowed to cross said bridge; and that said bridge shall not interfere with the free navigation of said river beyond what is necessary in order to carry into effect the rights and privileges hereby granted; and in case of any litigation arising from any obstruction, or alleged obstruction, to the free navigation of said river, the cause may be tried before the district or circuit court of the United States of any State in or opposite to which any portion of said obstruction or bridge may be.

SEC. 2. That the incorporators named in the above incorporation shall hold the said charter here granted in trust for the sole and exclusive use and benefit of any person or persons, company or companies, corporation or corporations, who shall build, erect, and complete such bridge herein provided in accordance with the provisions of this act; and said original incorporators shall transfer and assign, without any remunerative compensation, all their rights to any party or parties, company or companies, corporation or corporations, who shall erect said bridge; and if said corporators, or any of them, shall refuse or fail to make such transfer, upon the payment of the reasonable expenses thereof, they may be compelled to do so by any

court having jurisdiction: PROVIDED, That the said Nebraska City Bridge Company, and their associates, shall fail to commence in good faith the erection of said bridge within one year from the passage of this act, and complete the said bridge without unnecessary and unreasonable delay in accordance with the provisions of this charter.

SEC. 3. That any bridge built under the provisions of this act, may, at the option of person or persons, or corporation building the same, be built as a drawbridge, with a pivot-draw, or with unbroken or continuous spans: PROVIDED, That if the same shall be made of unbroken or continuous spans, it shall not be of less elevation, in any case, than fifty feet above extreme high water mark, as understood at the point of location, to the bottom chord of the bridge, nor shall the spans of said bridge be less than two hundred and fifty feet in length; and the piers of said bridge shall be parallel with the current of the river, and the main span shall be over the main channel of the river, and not less than three hundred feet in length: AND PROVIDED ALSO, That if a bridge shall be built under this act as a drawbridge, the same shall be constructed as a pivot drawbridge, with a draw over the main channel of the river at an accessible and navigable point, and with spans of not less than one hundred and sixty feet in length in the clear on each side of the central or pivot pier of the draw, and the next adjoining spans to the draw shall not be less than two hundred and fifty feet; and said spans shall not be less than thirty feet above low water mark, and not less than ten feet above extreme high-water mark, measuring to the bottom chord of the bridge, and the piers of said bridge shall be parallel with the current of the river: AND PROVIDED ALSO, That said draw shall be opened promptly, upon reasonable signal, for the passage of boats whose construction shall not be such as to admit of their passage under the permanent spans of said bridge, except when trains are passing over the same, but in no case shall unnecessary delay occur in opening the said draw during or after the passage of trains: AND PROVIDED FURTHER, That the corporation building said bridge may, if not unauthorized by the provisions of its charter of incorporation, enter upon the banks of said

river, either above or below the point of the location of said bridge, for a distance of seven miles, and erect and maintain break-waters, or use such other means as may be necessary to make a channel for said river, and confine the flow of the water to a permanent channel, and to do whatever may be necessary to accomplish said object, but shall not impede or obstruct the navigation of the said river; and all plans for such works or erections upon the banks of the river shall first be submitted to the Secretary of War for his approval.

SEC. 4. That any bridge constructed under this act, and according to its limitations, shall be a lawful structure, and shall be known and recognized as a post-route, upon which, also, no higher charge shall be made for the transmission over the same of the mails, the troops, and the munitions of war of the United States than the rate per mile paid for their transportation over the railroads or public highways leading to the said bridge.

SEC. 5. That all railway companies desiring to use the said bridge shall have and be entitled to equal rights and privileges in the passage of the same, and in the use of the machinery and fixtures thereof, and of all the approaches thereto, under and upon such terms and conditions as shall be prescribed by the Secretary of War upon hearing the allegations and proofs of the parties in case they shall not agree.

SEC. 6. That the plan and specifications, with the necessary drawings of said bridge, shall be submitted to the Secretary of War, for his approval, and until he approve the plan and location of said bridge it shall not be built or commenced; and should any change be made in the plan of said bridge during the progress of the work thereon, such change shall be subject to the approval of the Secretary of War; and all changes in the construction of said bridge that may be directed by Congress shall be made at the cost and expense of the owners thereof.

SEC. 7. That the right to alter or amend this act, so as to prevent or remove all material obstructions to the navigation of said river by the construction of bridges, is hereby expressly reserved.

Approved, June 4, 1872.

## APPENDIX B.—CONTINUED.

## CONTRACT WITH WAR DEPARTMENT.

WHEREAS, by an Act of Congress approved June 4, 1872, entitled "An Act authorizing the construction of a bridge across the Missouri River opposite to, or within the corporate limits of Nebraska City, Nebraska," it was enacted that it shall be lawful for the Nebraska City Bridge Company, a corporation having authority from the State of Nebraska and from the State of Iowa, to build a railroad, transit and wagon bridge across the Missouri River, opposite to or in the immediate vicinity of Nebraska City, in the county of Otoe, and State of Nebraska; and

WHEREAS, it is provided by Section 2 of said act, "That the corporators named in the above corporation shall hold the said charter here granted in trust for the sole and exclusive use and benefit of any person or persons, company or companies, corporation or corporations who shall build, erect and complete such bridge herein provided in accordance with the provisions of this Act, and said original incorporators shall transfer and assign, without any remunerating compensation, all their rights to any party or parties, company or companies, corporation or corporations, who shall erect said bridge;" and

WHEREAS, it is further provided by the Act of Congress aforesaid, that the corporation building said bridge may enter upon the banks of said river, either above or below the point of location of said bridge, and erect and maintain breakwaters or use such other means as may be necessary to make a channel for said river, and to confine the flow of the water to a permanent channel, and to do whatever may be necessary to accomplish said object, but shall not impede or obstruct the navigation of said river; and all plans for such works or erections upon the banks of the river shall first be submitted to the Secretary of War for his approval; and further, that the plan and specifications, with the necessary drawings of said bridge, shall be submitted to the Secretary of War for his approval, and until he approves the plan and location of said bridge, it shall not be built or commenced; and should any

change be made in the plan of said bridge, during the progress of the work thereon, such change shall be subject to the approval of the secretary of War; and

WHEREAS, the Nebraska City Bridge Company, in pursuance of the Act of Congress aforesaid, and in consideration that the Nebraska Railway Company, a corporation in the State of Nebraska, shall immediately enter upon the construction of said bridge, and shall complete the same without unnecessary delay, and shall thereafter maintain the said bridge, the aforesaid, the Nebraska City Bridge Company, by its president and secretary, has conveyed to the Nebraska Railway Company aforesaid, all the rights, title, charter, privileges and franchise that is or ever has been vested in the said Nebraska City Bridge Company; and

WHEREAS, the Nebraska Railway Company has accepted the transfer of all the rights, title, charter and privileges conferred upon the said Nebraska City Bridge Company by the Act of Congress aforesaid, and has also accepted all of the provisions, restrictions and limitations of the Act of Congress aforesaid, in regard to the construction of said bridge, and subject to the further condition that in the event of the Nebraska Railway Company failing to comply with the conditions of construction and the terms of the transfer as aforesaid, the rights and privileges so transferred shall revert to the Nebraska City Bridge Company aforesaid; and

WHEREAS, the Nebraska Railway Company, in pursuance of the act of Congress aforesaid, has submitted for the approval of the Secretary of War a map showing the location of said bridge, and the works designed to confine the flow of the water to a permanent channel, together with the plan and specifications and a drawing of said bridge; and

WHEREAS, the Acting Chief of Engineers, United States Army, has reported that the papers now presented are believed to fulfill all the requirements of the case, and are recommended for approval:

Now, therefore, I, William C. Endicott, Secretary of War, having examined the plans and specifications for the construction of said bridge, and the map of location of

said bridge, and the works designed to confine the flow of the water to a permanent channel, submitted by the Nebraska Railway Company, do hereby approve the same, subject to the condition, however, that the engineer officer of the United States Army in charge of the district within which the bridge is to be erected, may supervise its construction, so far as may be necessary, in order that the plans approved by the Secretary of War shall be complied with, and the bridge built accordingly.

Witness my hand this 5th day of July, 1887.

WM. C. ENDICOTT,  
*Secretary of War.*

The words "of the United States Army" in line ten of this page were inserted before the execution of this instrument.

This instrument is also executed by the Nebraska Railway Company, by its president, G. W. Holdrege, thereto lawfully authorized, this twenty-seventh day of June, 1887, in testimony of its acceptance of the provisions, conditions and limitations of the Act of Congress aforesaid.

THE NEBRASKA RAILWAY COMPANY,  
By G. W. HOLDREGE,  
*President.*

In presence of

H. D. ALLEE,  
P. S. EUSTIS,  
THOMAS MILLER.

Attest: J. G. TAYLOR,  
*Secretary.*

## APPENDIX C.

## SPECIFICATIONS FOR MASONRY.

There will be two masonry piers and one abutment.

The masonry will be first-class rock face work laid in regular courses.

The piers and abutment shall conform in all respects to the plans furnished by the Engineer. The face stones, including coping, above the elevations designated on the plans, shall be of granite from the quarries near Morton, Minnesota. All other stone shall be limestone from the quarries near Mankato, Minnesota.

Four lines of four-inch vitrified drain-pipe shall be laid through the front wall of the abutment at the first masonry joint.

The stone shall be cut and coursed out at the quarries, every dimension stone being marked, and full course plans being sent at time of shipment.

No course shall be less than sixteen inches thick and no course shall be thicker than the course below it. The upper and lower bed of every stone shall be at least one quarter greater in both directions than the thickness of the course, and no face stone shall measure less than thirty inches in either horizontal direction.

In general, every third stone of each course shall be a header, and there shall be at least two headers on each side of each course between the shoulders. No stone will be considered a header that measures less than five feet back from the face. The headers shall be so arranged as to form a bond entirely through the pier, either by bonding against a face stone on the opposite side of the course, or by bonding with a piece of backing not less than three feet square which shall bond with a face stone on the opposite side. In all cases the interior bonding shall be further secured by placing in the course above a stone at least three feet square over the interior joints. Special care shall be taken with the bonding of the ice-breaker cut water, the stones of which shall be so arranged that the face stones are supported from behind by large pieces of backing.

All joints shall be pitched to a true line and dressed to one-quarter inch for at

least twelve inches from the face. Beds, both upper and lower, shall be pitched to a true line and dressed to one-quarter inch. Joints shall be broken at least fifteen inches on the face. The bottom bed shall always be the full size of the stone.

The face of the up-stream starlings of Piers II and III shall be fine-pointed, with no projections exceeding one-half inch. There shall be a draft line three inches wide around the lower edge of the belting course below the coping, and on the edge of the down stream starling of Piers II and III. The coping over the whole pier and the small copings over the pointed starlings of Piers II and III shall have a smooth cut surface and face. All other parts of the work shall have a rough quarry face, with no projections exceeding three inches from the pitch line of the joints.

The stones in the coping under the bearings of the trusses shall be built according to special plans, to be furnished by the Engineer. They shall have good beds for their entire sizes, and a full bearing on large stones with dressed beds in the belting course below the coping.

The stones of the backing shall be of the same thickness as the face stone, and shall have dressed beds. All stone shall be sound, free from seams or other defects, and all limestone shall be laid with the natural beds horizontal.

All stone shall be laid in full mortar beds. They shall be lowered on the bed of mortar and brought to a bearing with a maul. No spalls will be allowed except in small vertical openings in the backing. Thin mortar joints will not be insisted on, but the joint shall be properly cleaned on the face and pointed in mild weather, the pointing to be driven in with a calking iron.

The face stones of each course in Piers II and III for a height of 26 feet, beginning about three feet below low water, shall be doweled into those of the course below with round dowels of 1½-inch iron, extending six inches into each course; the

dowels shall be from eight to twelve inches back from the face, and six inches on each side of every joint; the stones of the upper course shall be drilled through before setting, after which the drill hole shall be extended six inches into the lower course; a small quantity of mortar shall then be put into the hole, the dowel dropped in and driven home, and the hole filled with mortar and rammed. The three courses below the copings to have the joints bound with cramps of ¾-inch round iron, 20 inches long between shoulders, the ends sunk three inches into each stone.

The mortar will be composed of cement and clean coarse sand satisfactory to the Engineer, in proportion varying from one to three parts of sand to one of cement, as may be directed by the Engineer for different parts of the work. When stone is laid in freezing weather, the contractor shall take such precautions to prevent the mortar's freezing as shall be satisfactory to the Engineer.

No material shall be measured or included in the estimate, which does not form a part of the permanent structure.

All necessary tools and materials of every description whatsoever, except cement, shall be furnished by the contractor. The cement will be furnished by the Railroad Company, the contractor taking the same from the storehouse.

The Railroad Company will pay for the transportation of the stone from Des Moines, Iowa, to the bridge site, but any stone transported and left over from the work will be the property of the Railroad Company.

In the approximate monthly estimates, stone quarried but not cut, shall be estimated at four dollars per cubic yard, and stone quarried and cut, at eight dollars per cubic yard, these prices being simply assumed for the purpose of estimating unfinished work.

July 16th, 1887.

APPENDIX D.

RECORD OF SINKING CAISSONS.

PIER I.

Date.	ELEVATIONS OF CUTTING EDGE.					Sunk in 24 Hrs.	ELEVATIONS OF GROUND.					Average Penetration of Caisson.	Water Gauge.	Depth Immersed	WEIGHTS.											AIR PRESSURE.		Re-action Due to Air Pressure.	Net Weight	Sur-face in Con-tact.	Av. Wt. per sq. ft. on surface ex-posed to Frict'n	REMARKS.									
	N. E.	N. W.	S. E.	S. W.	Average.		N. E.	N. W.	S. E.	S. W.	Average.				F E-C Ft.	G	H G-C Ft.	Caisson.			Crib.			Air Lock, Shaft, etc.	Mas-on-ry.	Sand.	Water.						Total.	Indi-cated.	Calcu-lated.	K	L	M L x A Tons.	N I-M Tons.	O Sq. Ft.	P N+O Tons.
																		Timber	Iron.	Con-crete.	Timber	Iron.	Con-crete.																		
1887 Dec. 8					C 500.87	D 2.63				E 501.3	F 3.06	G 503.2	H 4.96	70	14	162	23				2				271											A = area of base = (18 x 38 - [9 - 7.07]) = 582.07.					
9	498.83	498.19	498.81	498.13	498.24	2.63	501.4	501.2	501.4	501.3	3.06	503.2	4.96	70	14	162	23				2				271										Caisson built on shore; began taking out blocking at 8 a. m.						
10	493.31	493.15	493.70	493.49	493.41	4.83	500.3	498.4	500.4	501.2	6.79	503.2	9.79	70	14	162	23	1	192	5			4	1	472	7.0	4.2	206	266	744	715			Started air pumps at 11 a. m. Started sand pumps at 12 m. [Began concreting.							
11	487.90	487.75	487.40	487.35	487.60	5.81	504.1	500.8	504.1	503.5	15.50	503.25	15.65	70	14	162	35	2	327	5			18		633	8.5	6.8	334	299	1694	353										
12	483.83	483.66	483.37	483.15	483.50	4.10	502.5	503.3	503.5	502.9	19.50	502.8	19.30	70	14	162	42	2	531	6			32		859	12.0	8.3	408	451	2125	424										
13	481.49	481.38	481.23	481.08	481.29	2.21	502.5	503.0	503.0	502.8	21.61	502.8	21.51	70	14	162	48	2	531	6			43		876	10.5	9.3	457	419	2351	356										
14	477.33	477.38	477.60	477.61	477.48	3.81	499.8	502.8	502.8	502.8	25.02	502.8	25.32	70	14	162	75	4	838	8			62		1233	12.0	10.9	535	698	2711	515										
15	475.30	475.35	475.41	475.42	475.37	2.11	505.0	504.9	505.0	504.6	29.53	502.3	26.93	70	14	162	78	5	1023	8			89		1449	13.5	11.6	570	879	3183	552										
16	470.40	470.42	470.20	470.18	470.30	5.07	504.1	503.7	503.6	503.5	33.40	501.3	31.00	70	14	162	84	5	1023	8			120		1486	15.5	13.4	658	828	3583	462										
17	466.01	465.92	465.99	465.87	465.95	4.35	505.1	503.9	504.6	503.9	38.45	504.0	38.05	70	14	162	105	6	1285	9			163		1814	17.0	16.4	805	1009	4096	492										
18	461.68	461.37	461.93	461.58	461.64	4.31	503.5	503.7	503.1	502.7	41.56	504.7	43.06	70	14	162	120	6	1527	10			192	8	2109	19.0	18.6	913	1196	4403	543										
19	456.68	456.37	456.86	456.51	456.60	5.04	501.9	501.4	501.0	502.6	45.10	502.4	45.80	70	14	162	120	*15	1527	10			229	4	2151	20.0	19.8	972	1179	4757	496										
20	454.89	454.66	454.70	454.45	454.67	1.93	501.0	501.4	501.8	501.5	46.73	501.6	46.93	70	14	162	120	15	1527	10			252	1	2171	20.0	20.3	997	1174	4914	477										
21	454.89	454.66	454.70	454.45	454.67	.00	500.9	501.1	501.7	501.4	46.63	501.2	46.53	70	14	162	120	15	1527	10			251		2169	21.0	20.1	987	1182	4904	482										
22	453.96	453.73	453.74	453.47	453.72	.95	501.3	501.5	499.7	501.0	47.18	501.3	47.58	70	14	162	120	15	1527	10			260	2	2180	21.0	20.6	1012	1168	4961	471										
23	451.48	451.37	451.30	451.16	451.32	2.40	500.1	500.5	499.0	499.8	48.58	501.8	50.48	70	14	162	120	15	1527	10			275	12	2205	22.0	21.8	1071	1134	5997	445			Set bottom sections of cylinders.							
24	451.47	451.36	451.30	451.14	451.32	.00	500.0	499.3	497.3	499.0	47.58	501.7	50.38	70	14	162	126	10	1609	10			263	17	2281	22.5	21.8	1071	1210	5000	484										
25	449.20	449.09	448.98	448.84	449.03	2.29	497.7	498.0	495.9	498.1	48.37	502.1	53.07	70	14	162	131	10	1609	10			272	31	2309	23.5	22.9	1125	1184	5081	466										
26	449.20	449.09	448.97	448.83	449.02	.01	497.3	498.1	495.4	498.1	48.18	502.1	53.08	70	14	162	131	10	1609	10			270	32	2308	23.5	22.9	1125	1183	5059	467										
27	449.20	449.09	448.97	448.83	449.02	.00	497.3	498.1	495.4	498.1	48.18	502.1	53.08	70	14	162	131	12	1609	11			270	32	2311	24.0	22.9	1125	1186	5059	469										
28	449.19	449.07	448.97	448.82	449.01	.01	497.3	498.1	495.4	498.1	48.19	502.1	53.09	70	14	162	134	13	1679	11			270	32	2385	24.0	22.9	1125	1260	5059	498										
29	449.19	449.08	448.97	448.82	449.01	.00	497.3	498.1	495.9	497.1	48.09	501.9	52.89	70	14	162	134	*23	1679	11			269	32	2394	24.0	22.8	1120	1274	5049	504										
30	445.93	445.88	445.87	445.77	445.86	3.15	496.6	496.7	498.2	498.0	52.34	502.1	56.24	70	14	162	134	27	1694	11			321	27	2460	24.5	24.7	1213	1247	5834	427										
31	442.83	442.76	442.76	442.67	442.75	3.11	499.3	495.7	498.1	496.9	54.75	501.7	58.95	70	14	162	134	27	1694	11			353	51	2516	26.0	25.5	1252	1264	6087	415			Stopped sand pumps at 2:40 p. m.							
1888 Jan. 1	442.56	442.51	442.58	442.47	442.53	.22	499.3	495.7	498.1	496.9	497.5	54.97	501.7	59.17	70	14	162	134	27	1694	11			356	54	2522	26.0	25.6	1257	1265	6110	414									
2	442.41	442.36	442.46	442.36	442.40	.13	499.3	495.7	498.1	496.9	497.5	55.10	501.7	59.30	70	14	162	134	13	1694	11			358	55	2511	26.0	25.6	1257	1254	6125	409			Commenced sealing at 2 p. m.						
3	442.39	442.34	442.45	442.35	442.38	.02	499.3	495.7	498.1	496.9	497.5	55.12	501.7	59.32	70	14	162	134	13	1694	11			358	55	2511	26.0	25.6	1257	1254	6125	409									
4	442.39	442.34	442.45	442.35	442.38	.00	499.3	495.7	498.1	496.9	497.5	55.12	501.7	59.32	70	14	162	134	13	1694	11			358	55	2511	26.0	25.6	1257	1254	6125	409			Stopped air pumps at 7:35 a. m.						

\* Railroad iron piled on crib.

APPENDIX D.—CONTINUED.  
 RECORD OF SINKING CAISSONS.  
 PIER II.

Date.	ELEVATIONS OF CUTTING EDGE.					Sunk in 24 Hrs.	ELEVATIONS OF GROUND.					Average Penetration of Caisson.	Water Gauge.	Depth Immersed.	WEIGHTS.										AIR PRESSURE.		Re-action Due to Air Pressure.	Net Weight.	Surface in Contact.	Av. Wt. per sq. ft. on surface exposed to Friction.	REMARKS.									
	N. E.	N. W.	S. E.	S. W.	AVERAGE.		N. E.	N. W.	S. E.	S. W.	AVERAGE.				F E-C Ft.	G	H G-C Ft.	Caisson.			Crib.			Air Lock, Shaft, etc.	Masonry.	Sand.						Water.	Total.	Indicated.	Calculated.	M L×A Tons.	N I-M Tons.	O Sq. Ft.	P N+O Tons.	
1888					C	D					E	F	G	H	I	J	K	L	M	N	O	P	Q	R	S	T	U	V	W	X	Y	Z								
Jan. 10	503.54	503.58	503.59	503.62	503.58	.....	491.1	495.6	493.1	491.1	493.1	.....	501.6																					A=area of base=(24×54-[9×7.07])=1294.87.						
11	493.23	495.13	494.45	496.12	494.73	8.85	492.4	495.9	493.4	492.9	494.3	.....	501.9	7.17	132	23	97																	Lowering caisson. Began concreting.						
12	493.52	493.72	494.00	494.02	493.82	.01	492.4	495.9	493.4	492.9	494.0	.18	501.9	8.08	132	23	237																Started air pumps at 3:40 p. m.							
13	491.92	492.27	492.39	492.59	492.29	1.53	489.8	489.3	493.3	493.8	491.2	.....	501.8	9.51	132	23	237																Started sand pumps at 9:15 a. m.							
14	492.17	492.29	491.80	491.88	492.06	.23	489.9	489.4	493.4	493.9	491.5	.....	501.9	9.84	132	23	237																							
15	492.11	492.33	491.78	491.84	492.02	.04	489.3	489.8	493.3	493.8	491.6	.....	501.8	9.78	132	23	237																							
16	492.08	492.31	491.77	491.84	492.00	.02	489.4	489.9	493.4	493.9	492.2	.02	501.9	9.90	132	23	396																							
17	491.73	491.97	491.24	491.37	491.58	.42	492.9	491.4	492.9	494.4	493.6	2.02	501.9	10.32	132	23	396	6							1	4	569													
18	488.96	488.91	488.67	488.51	488.76	2.82	492.3	490.9	494.9	494.9	493.8	5.04	501.9	13.14	132	23	453	21	1	95	7						4	4	740							Commenced on crib.				
19	485.59	485.84	485.21	485.35	485.50	3.26	491.3	490.1	495.9	494.9	493.6	8.10	501.9	16.40	132	23	453	31	2	244	7			7	9	908														
20	485.56	485.84	485.20	485.34	485.49	.01	490.3	490.8	495.8	495.8	494.6	9.11	501.8	16.31	132	23	453	46	3	308	7					8	9	989												
21	484.68	484.98	484.99	485.14	484.95	.54	490.8	492.1	496.6	496.1	495.1	10.15	501.6	16.65	132	23	453	46	3	475	7					10	10	1159												
22	482.88	482.70	482.80	482.47	482.71	2.24	491.6	491.6	499.1	496.1	495.1	12.39	501.6	18.89	132	23	453	51	4	475	7					12	19	1176												
23	482.36	482.24	481.77	481.99	482.09	.62	490.5	495.0	499.5	497.5	497.5	15.41	501.5	19.41	132	23	453	66	5	640	8					18	18	1363												
24	476.48	476.56	476.82	476.77	476.66	5.43	494.4	497.9	498.4	498.4	498.4	21.74	501.4	24.74	132	23	453	66	6	799	8					78	17	1582												
25	476.27	476.34	476.09	476.01	476.18	.48	495.4	499.1	499.9	496.4	498.2	22.02	501.4	25.22	132	23	453	66	6	799	8					80	18	1585												
26	476.27	476.34	476.08	476.02	476.18	.00	497.2	498.7	498.7	496.7	498.1	21.92	501.2	25.02	132	23	453	66	6	799	8					79	17	1583												
27	476.28	476.33	476.07	476.00	476.17	.01	495.6	499.1	498.6	497.1	498.0	21.83	501.1	24.93	132	23	453	66	6	799	8					79	17	1583												
28	476.28	476.32	476.08	479.00	476.17	.00	495.0	498.5	498.6	497.0	497.7	21.53	501.0	24.83	132	23	453	66	6	799	8					76	18	1581												
29	476.27	476.33	476.08	476.00	476.17	.00	495.8	498.6	498.7	497.6	498.2	22.03	501.0	24.83	132	23	453	66	6	799	8				80	16	1583													
30	471.35	471.31	471.39	471.34	471.35	4.82	495.9	498.4	497.9	495.4	497.4	26.05	500.9	29.55	132	23	453	66	6	799	8	163	127	36	1813	10.0	10.7	997												
31	466.91	466.84	466.79	466.74	466.82	4.53	497.3	498.8	499.8	495.3	497.7	30.88	500.8	33.98	132	23	453	66	6	799	9	355	241	67	2151	12.0	12.8	1193												
Feb. 1	462.76	462.69	462.50	462.46	462.60	4.22	497.9	499.1	499.4	495.9	498.5	35.90	500.9	38.30	132	23	453	66	6	799	9	582	457	56	2583	14.0	14.7	1370												
2	457.20	457.14	456.91	456.87	457.03	5.57	496.6	497.0	500.6	494.5	497.7	40.67	501.1	44.07	132	23	453	66	6	799	10	778	674	82	3023	15.5	16.5	1537												
3	452.93	452.85	452.71	452.64	452.78	4.25	500.8	499.4	500.9	494.2	498.7	45.92	501.2	48.42	132	23	453	66	6	799	10	942	920	62	3413	18.5	19.0	1770												
4	449.89	449.80	449.87	449.78	449.83	2.95	501.1	500.1	499.1	500.1	497.7	47.87	501.1	51.27	132	23	453	66	6	799	11	1101	1013	85	3689	20.0	20.9	1947												
5	447.74	447.65	447.79	447.72	447.72	2.11	499.3	499.8	500.8	497.3	499.4	51.68	501.3	53.58	132	23	453	66	6	799	11	1255	1197	48	3990	21.0	22.1	2059												
6	446.66	446.56	446.77	446.65	446.66	1.06	.....	.....	.....	.....	.....	.....	501.4	54.74	132	23	453	66	6	799	11	1396	1249	51	4186	22.0	23.1	2152												
7	445.45	445.39	445.53	445.40	445.44	1.22	498.3	500.1	499.8	498.8	499.3	53.86	501.6	56.16	132	23	453	66	6	799	11	1396	1304	59	4249	22.0	23.6	2199												
8	445.18	445.12	445.24	445.17	445.18	.26	498.5	501.5	501.3	501.7	500.6	55.42	501.9	56.72	132	23	453	66	6	799	11	1396	1382	34	4302	23.0	24.5	2283												
9	444.94	444.87	445.00	444.94	444.94	.24	499.1	499.6	500.1	501.6	500.1	55.16	502.1	57.16	132	23	453	66	6	799	11	1396	1369	52	4307	23.5	24.7	2301												
10	444.70	444.63	444.71	444.66	444.65	.29	498.9	499.3	499.1	500.8	500.1	55.45	502.1	57.45	132	23	453	66	6	799	11	1396	1383	52	4321	23.5	24.8	2311												
11	444.38	444.32	444.37	444.31	444.34	.31	502.0	499.2	499.5	501.0	500.3	55.96	502.0	57.66	132	23	453	66	6	799	11	1396	1408	44	4338	23.5	24.9	2320												
12	444.04	443.96	444.10	444.02	444.03	.31	501.8	501.2	499.4	500.8	500.4	56.37	501.8	57.77	132	23	453	66	6	799	11	1396	1429	36	4351	23.5	25.0	2329												
13	443.65	443.55	443.72	443.63	443.64	.39	501.8	501.8	500.8	500.3	500.2	56.56	501.8	58.16	132	23	453	66	6	799	11	1396	1438	42	4366	24.0	25.1	2339												
14	443.30	443.23	443.33	443.24	443.27	.37	501.8	500.8	498.8	500.3	499.9	56.63	501.8	58.53	132	2																								

APPENDIX D.—CONTINUED.  
RECORD OF SINKING CAISSONS.  
PIER III.

Date.	ELEVATIONS OF CUTTING EDGE.					Sunk in 24 Hrs.	ELEVATIONS OF GROUND.					Average Penetration of Caisson.	Water Gauge.	Depth Immersed.	WEIGHTS.											AIR PRESSURE.		Reaction Due to Air Pressure.	Net Weight.	Sur-face in Con-tact.	Av. Wt. persq. ft. on surface ex-posed to Frict'n.	REMARKS.
	N. E.	N. W.	S. E.	S. W.	Average.		N. E.	N. W.	S. E.	S. W.	Average.				Caisson.		Crib.			Air Lock, Shaft, etc.	Mason-ry.	Sand.	Water.	Total.	Indi-cated.	Calcul-ated.						
															Timber	Iron.	Timber	Iron.	Con-crete.								Tons.					
1887 Nov. 3					C	D				E	F E—C Ft.	G	H G—C Ft.								I	K	L	M L × A Tons.	N I—M Tons.	O	P N + O Tons.	A=area of base=(24×54—9—7.07)=1294.87.				
					503.16		488.9	486.9	489.4	486.4	488.5		498.95																Lowering caisson. Began concreting.			
4					489.24	13.92	486.9	486.4	488.9	485.4	487.1		498.95	9.71	132	23	178															
5	487.25	486.35	488.55	487.25	487.30	1.94	486.4	482.9	487.4	486.9	485.5		498.95	11.65	132	23	332															
6	487.63	486.89	488.34	487.30	487.54	.24	483.8	491.8	484.8	485.3	484.5		498.85	11.31	132	23	332	6											Started air pumps at 6:45 a. m.			
7	486.62	486.02	485.29	486.15	486.02	1.52	488.9	489.9	490.9	483.9	489.0	2.98	498.95	12.93	132	23	451	26	2	60	6								Started sand pumps at 8 a. m.			
8	484.22	484.50	484.25	484.25	484.30	1.72	489.4	488.9	490.9	483.4	488.1	3.80	498.95	14.65	132	23	451	31	2	229	7											
9	481.36	481.33	481.58	481.28	481.39	2.91	488.4	489.4	490.9	481.9	487.4	6.01	498.95	17.56	132	23	451	41	3	319	7											
10	480.76	480.75	481.34	481.01	480.96	0.43	489.5	490.0	492.5	482.0	488.3	7.34	499.0	18.04	132	23	451	56	5	465	7											
11	476.95	477.12	476.89	476.78	476.93	4.03	489.5	490.0	493.0	483.0	488.5	11.57	499.0	22.07	132	23	451	66	5	648	8								Finished crib.			
12	474.58	474.90	474.11	474.17	474.44	2.49	489.0	489.1	493.1	483.1	488.5	14.06	499.1	24.66	132	23	451	75	7	904	8								Finished concreting crib.			
13	471.14	471.52	471.51	471.61	471.44	3.00	491.1	489.1	493.6	483.1	489.0	17.56	499.1	27.66	132	23	451	75	7	904	8											
14	471.12	471.51	471.51	471.60	471.44	.00	489.1	489.1	493.1	483.1	488.7	17.26	499.1	27.66	132	23	451	75	7	904	8									Began laying stone.		
15	471.12	471.49	471.50	471.58	471.42	0.02	491.9	489.6	493.6	491.6	490.9	19.48	499.1	27.68	132	23	451	75	7	904	8	58	55	47	1760	13.0	12.0	1118	642	2919	440	
16	467.71	467.88	467.80	467.76	467.79	3.63	489.0	489.0	493.0	493.0	490.3	22.51	499.05	31.26	132	23	451	75	7	904	8	258	87	66	2011	14.5	13.5	1258	753	3333	452	
17	462.71	462.86	463.09	463.09	462.94	4.85	489.1	487.1	494.1	491.6	489.5	26.56	499.1	36.16	132	23	451	75	7	904	9	412	134	145	2292	16.5	15.6	1453	839	3884	432	
18	458.98	459.12	458.99	458.99	459.02	3.92	489.0	491.0	490.0	494.0	489.9	30.88	499.0	39.98	132	23	451	75	7	904	9	567	200	198	2566	18.0	17.3	1612	954	4453	428	
19	454.84	455.05	455.07	455.14	455.03	3.99	489.1	489.9	490.5	493.9	490.1	35.07	499.0	43.97	132	23	451	75	7	904	9	691	364	213	2869	20.5	18.9	1761	1108	4909	451	
20	454.84	455.05	455.07	455.14	455.03	.00	489.1	489.8	491.0	493.8	490.4	35.37	498.9	43.87	132	23	451	75	7	904	9	691	377	201	2870	20.5	18.9	1761	1109	4940	449	
21	454.87	455.02	455.09	455.13	455.03	.00	489.2	489.7	491.2	493.7	490.7	35.67	498.7	43.67	132	23	451	75	7	904	9	775	390	189	2955	20.0	18.9	1761	1194	4970	480	
22	449.23	449.37	449.23	449.28	449.28	5.75	489.6	493.6	485.6	495.6	491.8	42.52	498.6	49.32	132	23	451	75	7	904	10	939	700	166	3407	22.0	21.3	1985	1422	5667	502	
23	445.62	445.89	445.40	445.58	445.62	3.66	491.0	494.0	489.0	496.0	492.9	47.28	499.0	53.38	132	23	451	75	7	904	11	1102	925	152	3782	24.0	23.1	2152	1630	6144	530	
24	445.08	445.37	444.96	445.18	445.15	.47	490.8	493.8	489.8	496.8	493.5	48.35	498.85	53.70	132	23	451	75	7	904	11	1154	974	134	3865	24.0	23.2	2162	1703	6250	545	
25	445.03	445.31	444.94	445.12	445.10	.05	490.7	494.7	488.7	496.7	493.4	48.30	498.8	53.70	132	23	451	75	7	904	11	1154	971	135	3863	24.0	23.2	2162	1701	6245	544	
26	444.99	445.29	444.94	445.11	445.08	.02	490.6	498.1	488.1	495.1	493.2	48.12	498.7	53.62	132	23	451	75	7	904	11	1154	963	138	3858	24.0	23.1	2152	1706	6228	548	
27												498.15			132	23	451	75	7	904	11	1154										
28	444.83	445.16	444.77	444.98	444.93	.15	491.9	499.4	489.4	496.4	494.7	49.77	499.4	54.47	132	23	451	75	7	904	11	1154	1051	119	3927	24.0	23.5	2190	1737	6391	543	
29	444.38	444.70	444.19	444.39	444.41	.52	491.7	498.7	488.7	495.7	494.2	49.79	498.7	54.29	132	23	451	75	7	904	11	1337	1052	114	4106	24.5	23.4	2180	1926	6393	602	
30	444.33	444.61	444.14	444.32	444.35	.06	493.3	499.3	488.3	497.3	494.8	50.45	499.3	54.95	132	23	451	75	7	904	11	1337	1083	114	4137	25.0	23.7	2208	1929	6458	597	
Dec. 1	444.29	444.59	444.11	444.27	444.31	.04	495.7	495.7	488.7	497.7	494.8	50.49	499.75	55.44	132	23	451	75	7	904	11	1337	1084	125	4149	25.0	23.9	2227	1932	6462	595	
2	443.76	444.08	443.58	443.76	443.79	.52	496.7	493.2	496.7	495.7	494.9	51.11	499.75	55.96	132	23	451	75	7	904	11	1337	1113	123	4176	25.0	24.2	2255	1921	6523	589	
3	443.17	443.54	443.01	443.20	443.23	.56	496.7	491.7	495.7	495.7	494.0	50.77	499.75	56.52	132	23	451	75	7	904	11	1337	1097	146	4183	25.0	24.4	2273	1910	6490	588	
4	442.80	443.11	442.77	442.96	442.91	.32							499.6	56.69																		
5	442.80	443.11	442.77	442.96	442.91	.00							500.8	57.89																Commenced sealing at 7:15 p. m.		
6	442.80	443.11	442.77	442.96	442.91	.00							500.4	57.49																		
7																														Stopped air pumps at 12:45 a. m.		



APPENDIX E.-CONTINUED.  
TIME, COST AND MATERIALS USED IN FOUNDATIONS.  
PIER II.

Table with columns: DATE, PRINCIPAL FOREMAN, NIGHT FOREMAN, SUB FOREMEN, LOCK TENDERS, PRESSURE MEN, COFFEE HOUSE MEN, COFFEE, SUGAR, CANDLES, RED LEAD, WICKING, COAL, LINSEED OIL, MASTER MECHANIC AND DAY ENGINEER, NIGHT ENGINEER, DAY PUMPMAN, NIGHT PUMPMAN, FIREMEN, COAL PASSERS, SACKING OUT, COAL FOR BOILERS, BLACK OIL, SIGNAL OIL, WASTE, TOTALS FOR EACH DAY, FEET SUNK EACH DAY, MATERIAL, WORTHING-TONS (Hrs. Run, No. Rev.), REV'S OF AIR-PUMPS, REMARKS. Rows include dates from Jan 10 to Feb 22, 1888, with various numerical entries for labor, materials, and costs.

Other expenses charged to sinking..... \$22.04  
\$702.54



## APPENDIX F.

### SPECIFICATIONS FOR SUPERSTRUCTURE.

#### GENERAL DESCRIPTION.

The superstructure will consist of two through spans and one deck span.

Each through span will be 400 feet long between centers of end pins, divided into fifteen panels of 26 feet eight inches each. The trusses will be 50 feet deep, and placed 22 feet apart between centers. Each span will weigh approximately 1 100 000 pounds.

The deck span will be 325 feet long between centers of end pins, and divided into thirteen panels of 25 feet each, the trusses being 37 feet deep and placed 20 feet apart between centers.

#### PLANS.

Full detail plans, showing all dimensions, will be furnished by the Engineer. The work shall be built in all respects according to these plans. The contractor, however, will be expected to verify the correctness of the plans, and will be required to make any changes in the work which are necessitated by errors in these plans, without extra charge, where such errors could be discovered by an inspection of the plans.

#### MATERIAL.

All parts, except nuts, swivels, wall pedestal plates and ornamental work, will be of steel. The nuts and swivels may be of wrought iron; the pedestal plates and ornamental work of cast iron. The web plates of the East Approach Span may be of wrought iron.

All materials shall be subject to inspection at all times during their manufacture, and the Engineer and his inspectors shall be allowed free access to any of the works in which any portion of the material is made. Timely notice shall be given to the Engineer, so that inspectors may be on hand.

**STEEL.** Steel may be made by the open hearth or by the Bessemer process, but no steel shall be made at works which have not been in successful operation for at least one year. Steel made by the Clapp-Griffiths process will not be accepted. All melts shall be made from uniform stock low in phosphorus, and the manufacturer shall furnish satisfactory evidence to the Engineer that this class of material is being employed, it being understood that the finished product is to be one in which the phosphorus does not average more than  $\frac{1}{800}$  of one per cent. and never exceeds  $\frac{1}{100}$  of one per cent.

A sample bar  $\frac{1}{2}$  inch in diameter shall be rolled from every melt, the method of obtaining the piece from which this sample bar is rolled shall be the same for all samples, and the amount of work on this sample bar shall be as nearly as

practicable the same as on the finished product. The laboratory tests shall be made on this sample bar in its natural state without annealing.

The laboratory tests of steel made on the sample bar shall show an elastic limit of not less than 40 000 pounds per square inch; an ultimate strength of not less than 67 000 pounds nor more than 75 000 pounds per square inch; an elongation of at least 20 per cent. in a length of eight inches; and a reduction of at least 42 per cent. at the point of fracture; this elongation and reduction being the minimum and not the average requirements. In a bending test the sample bar shall bend 180 degrees and close back against itself without showing crack or flaw on the outside of the curve. Steel having an ultimate strength of 60 000 pounds per square inch will be accepted for rivets.

Should the contractor desire to use British steel, the quenching and bending tests specified in the Hawksbury Bridge specifications will be required, and the elastic limit requirement may be waived.

Every piece of steel shall be stamped with a number identifying the melt, and a statement of the results of the laboratory tests of each melt shall be furnished by the contractor, certified by some person acceptable to the Engineer, and accompanied by the tested specimens. Tests shall also be made from time to time on samples cut from finished plates, shapes and bars, which shall show results substantially conforming to those shown by the sample tests of the same melts.

All sheared edges or punched holes in steel work shall be subsequently planed or drilled out, so that none of the rough surface is ever left upon the work. Steel for pins shall be sound and entirely free from piping.

**WROUGHT IRON.** Small samples, having a minimum length of eight inches, shall show an elastic limit of at least 24 000 pounds, an ultimate strength of at least 47 000 pounds per square inch, an elongation of at least ten per cent, and a reduction of 15 per cent at the point of fracture.

**CAST IRON.** Cast iron shall be the best quality of tough, grey iron.

#### RIVETED WORK.

All plates, angles and channels shall be carefully straightened before they are laid out; the rivet holes shall be carefully spaced in truly straight lines; the rivet heads shall be of hemispherical pattern, and the work shall be finished in a neat and workmanlike manner. Surfaces in contact shall be painted before they are put together. The dimensions given for rivets on the plans are the diameters of the rivets before driving.

Power riveters shall be direct acting machines, capable of exerting a yielding pressure, and holding on to the rivet when the upsetting is completed.

The several parts of each member shall be assembled, and the holes shall be

drilled, the sharp edge of the drilled hole shall be trimmed so as to make a slight fillet under the rivet head, and the pieces shall be riveted together without taking apart. Should the contractor desire the parts may be punched with a punch at least  $\frac{3}{32}$  inch smaller than the diameter of the rivet as given on the plans, working in a die only  $\frac{1}{16}$  inch larger than the rivet; the several parts of the member shall then be assembled and the holes reamed so that at least  $\frac{1}{16}$  inch of metal is taken out all around, and the sharp edge of the reamed hole shall be trimmed and the pieces riveted together as above. All rivets shall be steel; the rivet holes shall be of such size that the rivet will fill the hole before driving, and, whenever possible, the rivets shall be driven by power. All bearing surfaces shall be truly faced. The chord pieces shall be fitted together in the shop, in lengths of at least five panels, and marked. When so fitted there shall be no perceptible wind in the length laid out. The pin holes shall be bored truly, so as to be at exact distances, parallel with one another, and at right angles to the axis of the member.

The holes for the rivets connecting the floor-beams with the posts and bolsters and the stringers with the floor-beams, and, in general, the holes for all rivets which must be driven after erection, shall be accurately drilled to an iron templet. The holes for rivets connecting the floor-beams with the posts shall be one inch in diameter, and the rivets of corresponding diameter. The pin holes in the vertical posts shall be truly parallel with one another and at right angles to the axis of the posts. The posts shall be straight and free from wind.

#### FORGED WORK.

The heads of eye-bars shall be formed by upsetting and forging into shape by such process as may be accepted by the Engineer. No welds will be allowed. After the working is completed, the bars shall be annealed by heating them to a uniform dark red heat throughout their entire length, and allowing them to cool slowly. The form of the heads of steel eye-bars may be modified to suit the process in use at the contractor's works, but the form of the head adopted must be such as to meet the requirements of the tests of full-sized bars.

The heads and the enlarged ends for screws in laterals, suspenders and counters, shall be formed by upsetting by a process acceptable to the Engineer.

#### TESTS OF FULL-SIZED STEEL BARS.

Ten full-sized eye-bars of sections and lengths, used in the actual work, shall be selected from bars made for the bridge, by the inspector for testing. Each of these full-sized bars shall be strained till an elongation of ten per cent. is obtained, and, if possible, broken. If broken, the fracture shall occur in the body of the bar, and shall show a uniform and ductile quality of material.

APPENDIX F—CONTINUED

The contractor will be required to furnish facilities for testing full-sized bars, within a reasonable distance of his works. Should the contractor be unable to furnish such facilities, he shall be required to furnish bars at 20 per cent. larger sections than those called for, without charge for the increased weight.

The full-sized bars shall be selected from time to time as the work proceeds, the best bar not to be selected till all the eye-bars are manufactured. The tests shall be made from time to time as the bars are selected. When three bars have been tested, the bars manufactured up to the time of the selection of these three test bars shall be accepted or rejected on the results of such tests, and the same shall be done again when three more bars are tested. In these tests, the failure of one bar to develop a stretch of eight per cent., or of the lot to develop an average of ten per cent. before breaking, shall be sufficient reason for rejecting the lot from which these bars are taken. A failure to break in the body of the bar shall not be sufficient ground for condemnation if it does not occur in more than one-third of the bars tested; but the above requirements as to elongation shall apply to the bars so breaking in the head, as well as to the others. The Engineer shall, however, examine carefully into the cause of breakage of any bar which does not meet the requirements, and, if the defect is explained, may order additional tests, and make the acceptance dependent on further results.

MACHINE WORK.

The bearing surfaces in the top chord shall be truly faced. The ends of the stringers and of the floor-beams shall be squared in a facer. All surfaces, so designated on the plans, shall be planed. All sheared and punched edges shall be planed or bored out.

All pins shall be accurately turned to a gauge, and shall be of full size throughout. Pins more than four inches in diameter shall be drilled through the axis. Pin-holes shall be bored to fit the pins, with a play not exceeding  $\frac{1}{30}$  of an inch. These clauses apply to all lateral connections as well as to those of the main trusses. Pins shall be supplied with pilot nuts, for use during erection, four of each size of pin.

All screws shall have a truncated V thread, United States standard sizes.

MISCELLANEOUS.

All workmanship and material, whether particularly specified or not, must be of the best kind now in use in first-class bridge work. Flaws, ragged edges, surface imperfections or irregular shapes will be sufficient ground for rejection. Rough and irregularly finished work will not be accepted.

Machine finished surfaces shall be coated with white-lead and tallow before shipment. All other parts shall be given a coat of hot boiled linseed oil.

TERMS.

Monthly estimates will be made at the end of each month for the work done during that month. In these monthly estimates the material delivered at the contractor's shop, but not manufactured, shall be estimated at 50 per cent. of the contract price for finished material in Chicago, and manufactured material at 75 per cent. of the contract price for finished material in Chicago. Payments will be made on or about the 15th day of the following month, according to these estimates, deducting from the amount of the same ten per cent. as security, to be held until the completion of the entire contract.

No material will be paid for which does not form a part of the permanent structure.

All expenses of testing shall be borne by the contractor.

TIME.

The trusses of the first through span shall be completed and shipped by January 1st, 1888; those of the second through span by January 20th, 1888, and the whole work by February 10th, 1888. The railroad company may exact a penalty, not exceeding \$150 per day, for failure to complete the work at these specified times. July 16th, 1887.

Width. Inches.	Number
6	
5	
5	
7	
7	
7	
7	
7	
4	
4	
4	
4	
4	
6	
7	
7	
4	
4	
7	
7	
4	
4	
7	
7	
5	
7	

# APPENDIX G.

## TESTS OF STEEL EYE-BARS.

TESTS ON FULL SIZED EYE-BARS.													TESTS ON SAMPLE BARS FROM SAME MELTS.								REMARKS.		
DIMENSIONS, INCHES.						RESULTS OF MECHANICAL TESTS.							TESTS ON SAMPLE BARS FROM SAME MELTS.										
Original.			After Test.			Reduction of Area, Per Cent.	Elongation.		Elastic Limit, Lbs. per sq. inch.	Maximum Load, Lbs. per sq. inch.	Place of Fracture.	Diameters.		Reduction, Per Cent.	Elongation, Per Cent.	Elastic Limit, Lbs. per sq. inch.	Maximum Load, Lbs. per sq. inch.	Per Cent of Phosphorus.	Heat Number.				
Nominal.	Actual.		After Test.		Inches.		Per Cent.	Original, Inches.				After testing, Inches.											
Width, Inches.	Thickness, Inches.	Length C to C.	Gauged Length.	Width.	Thickness.	Width.	Thickness.																
6	1	320.03	276	6.11	1.01	5.01	0.70	43.1	32.15	11.6	48920	74050	Body.	.750	.557	44.84	27.0	42100	74700	0.080	16903		
5	1½	438.78	396	5.08	1.26	3.80	0.89	47.2	48.70	12.3	37290	60550	"	.....	.....	.....	.....	.....	.....	.....	Not found.		
5	1½	438.63	396	5.08	1.26	3.92	0.92	43.6	39.60	10.0	38560	62140	"	.....	.....	.....	.....	.....	.....	.....	.....	"	
7	1½	319.98	276	7.09	1.73	5.47	1.31	41.6	36.80	13.3	40760	66820	"	.745	.520	51.28	27.5	42810	69970	0.075	17478		
7	2½	320.00	288	7.11	2.11	6.76	2.01	9.4	31.20	10.8	40384	67171	"	.748	.563	43.36	24.0	42560	73740	0.069	16914		
7	2½	320.00	288	7.13	2.13	5.63	1.58	41.5	38.75	13.4	41624	70627	"	.758	.540	49.26	25.0	41000	71460	0.067	16928		
7	1½	319.98	288	7.10	1.72	5.45	1.16	48.2	45.20	15.7	37585	63650	"	.761	.525	52.40	24.5	41120	70360	0.069	23114		
4	¾	439.23	372	4.03	0.73	3.92	0.72	4.1	17.80	4.8	41620	56190	"	.754	.485	56.63	29.50	41440	67190	0.080	6119	Counter. Broke in clamp marks near screw.	
4	¾	439.88	372	4.02	0.76	3.95	0.74	4.3	7.70	2.1	39454	46141	"	.755	.505	55.26	30.00	41880	68130	0.076	6122	Counter. Broke in clamp marks near screw.	
4	¾	370.43	336	4.00	0.75	3.10	0.50	48.3	27.10	8.1	42830	63910	"	.755	.505	55.26	30.00	41880	68130	0.076	6122	Retest of above after reupsetting, reannealing and removing clamp marks.	
4	¾	439.33	372	4.03	0.74	3.86	0.71	8.1	33.60	9.0	41065	62966	"	.754	.485	56.63	29.50	41440	67190	0.080	6119	Counter. Broke in grip marks near head.	
4	¾	327.99	312	3.76	0.71	3.07	0.46	47.2	.05	0.0	50450	71800	"	.754	.485	56.63	29.50	41440	67190	0.080	6119	Retest of above after reheating, but not reannealing. Broke between grip	
6	1	320.08	288	6.11	1.00	.....	.....	.....	29.40	10.3	49404	74440	Eye	.....	.....	.....	.....	.....	.....	.....	Not found.	Foreign substance in eye. [marks and eye.	
7	1½	300.08	264	7.10	1.73	.....	.....	.....	4.80	2.2	34215	40300	"	.747	.525	50.61	24.5	41070	69140	0.073	18118		
7	1½	259.43	228	7.02	1.71	5.33	1.05	53.4	24.60	10.8	38240	58980	Body.	.747	.525	50.61	24.5	41070	69140	0.073	18118	Retest of above, reheated and reannealed.	
4	¾	387.99	372	3.96	0.77	3.06	0.52	47.9	55.70	15.0	40120	66200	"	.....	.....	.....	.....	.....	.....	.....	Not found.		
4	¾	387.99	372	3.96	0.76	3.08	0.55	43.5	54.60	14.6	42010	67760	"	.....	.....	.....	.....	.....	.....	.....	.....	"	
7	1½	300.08	264	7.09	1.71	.....	.....	.....	5.90	2.2	38705	47120	Eye.	.752	.519	52.35	27.3	43570	71880	0.061	23113	Broke in flaw. } On these tests first set of eye bars made for deck span were	
7	2	300.03	264	7.11	2.00	6.95	1.88	8.1	11.20	4.3	33133	44900	Head.	.750	.514	53.03	28.3	41530	67460	0.074	18101	rejected.	
4	¾	437.58	372	4.02	0.75	3.02	0.44	56.0	23.40	6.3	42550	60110	Body.	.760	.515	54.08	28.75	41230	68120	0.075	25299	Counter. Broke in short end.	
4	¾	.....	372	4.02	0.75	3.07	0.50	49.3	43.60	11.7	42550	64830	"	.760	.515	54.08	28.75	41230	68120	0.075	25299	Long end of previous test.	
7	1½	299.88	264	7.04	1.75	5.32	1.11	52.1	40.20	15.2	42550	71850	"	.....	.....	.....	.....	.....	.....	.....	Not found.		
7	1½	299.58	264	7.02	1.75	5.18	1.08	54.5	37.80	14.3	39695	62120	"	.750	.545	47.20	25.5	42560	67910	0.050	564		
5	1	373.48	336	5.01	0.98	3.83	0.66	48.5	52.90	15.7	34480	58155	"	.740	.504	53.62	28.5	42090	68990	0.050	620		
7	2	300.08	264	7.01	2.01	5.12	1.22	55.8	39.10	14.8	32570	56890	"	.737	.517	50.80	24.5	43370	67980	0.050	679		





C.B. & Q.R.R.  
NEBRASKA CITY BRIDGE  
GENERAL MAP

SHORE LINE BY SURVEY  
FEBRUARY 1889

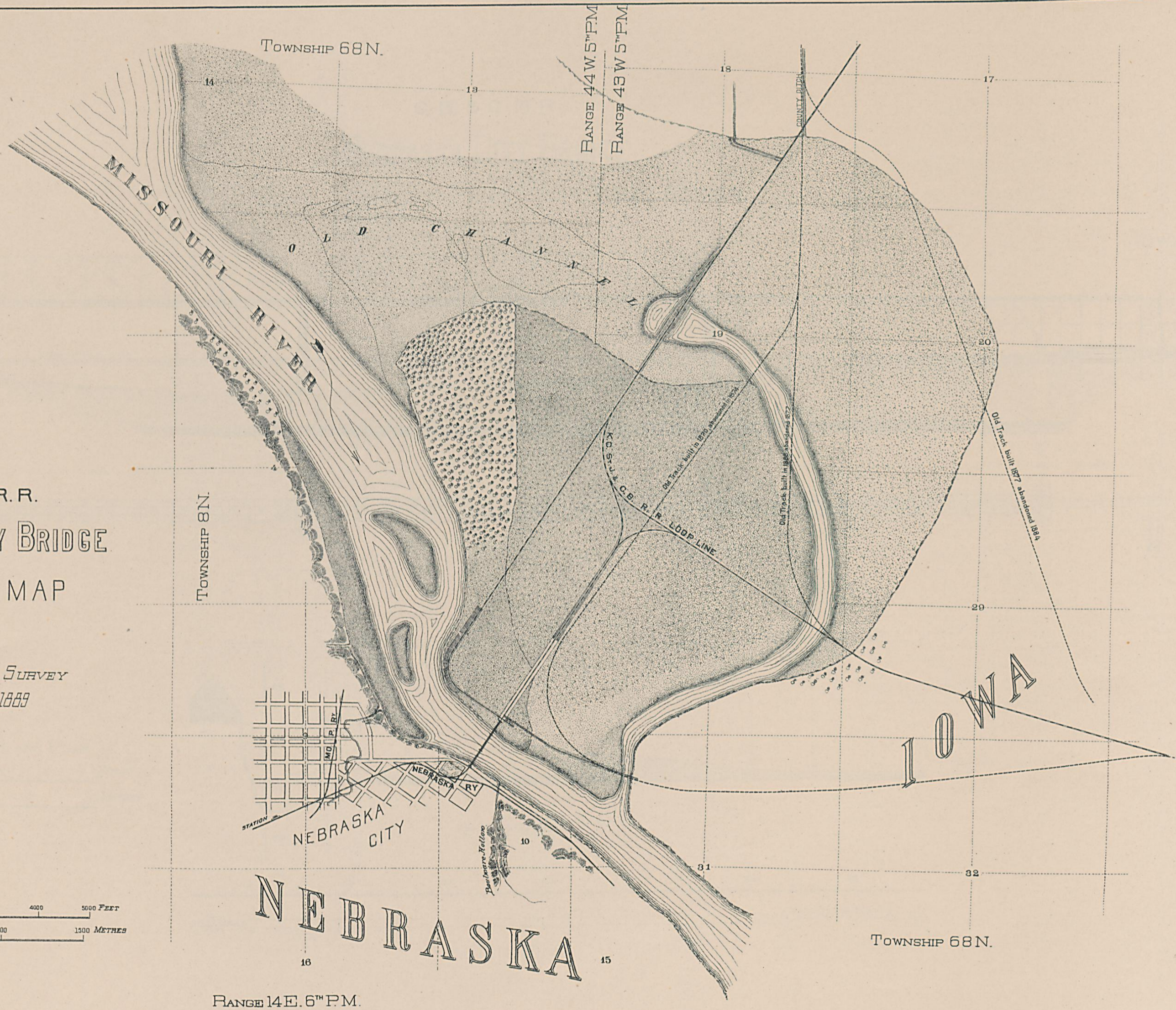
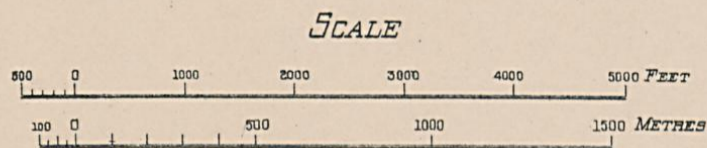

RANGE 14E. 6<sup>th</sup> P.M.

TOWNSHIP 68N.

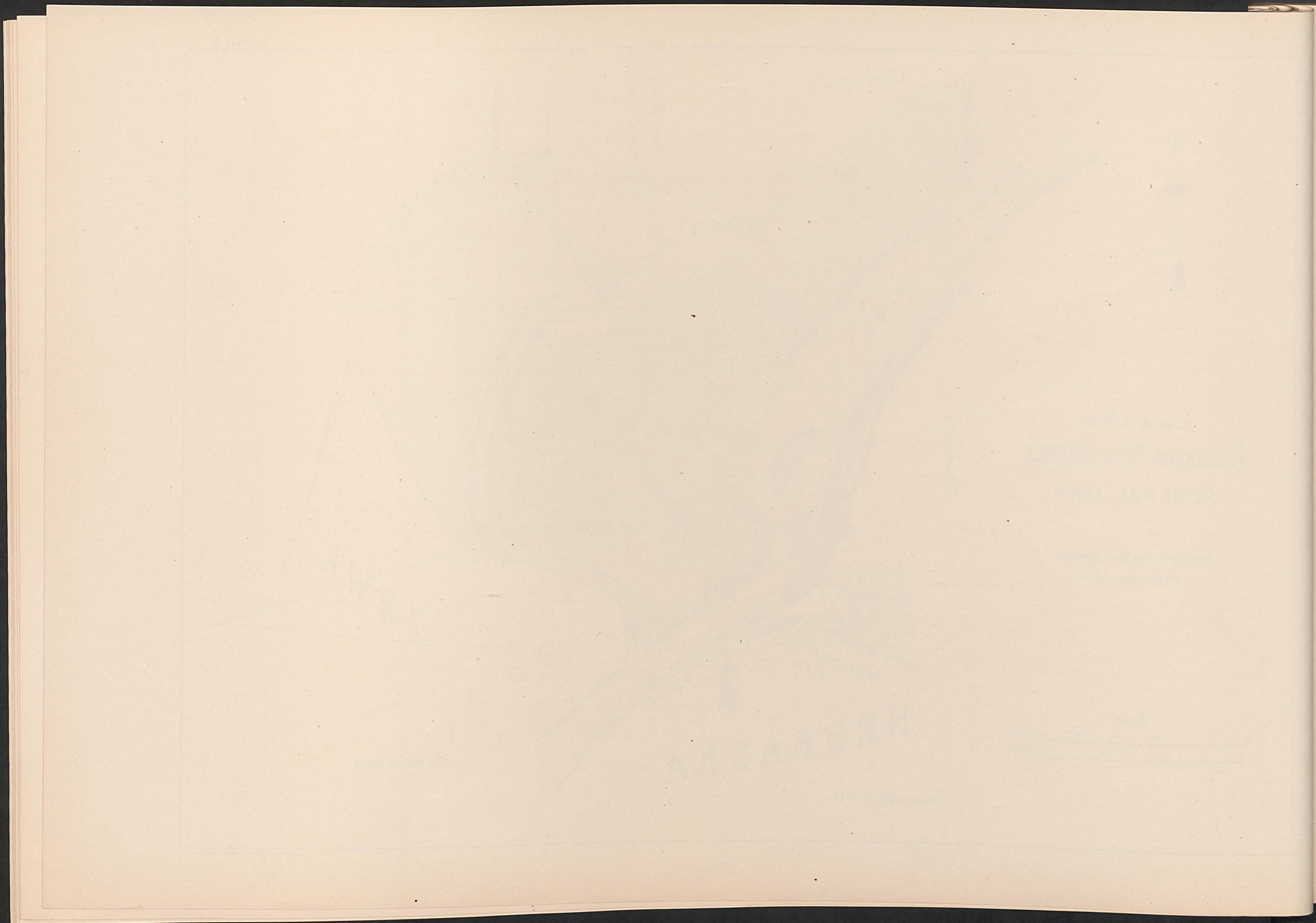

C. B. & Q. R. R.  
NEBRASKA CITY BRIDGE  
GENERAL ELEVATION PLAN PROFILE & ALIGNMENT

NEBRASKA

IOWA

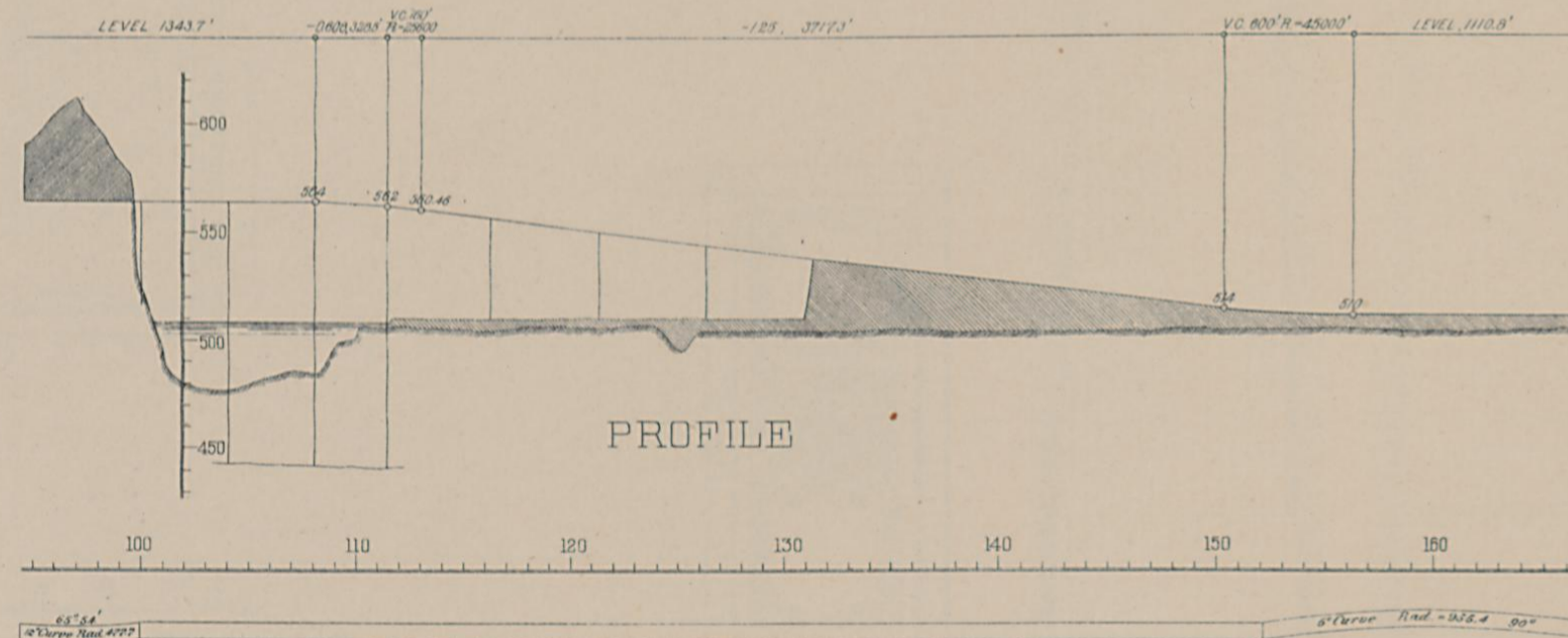
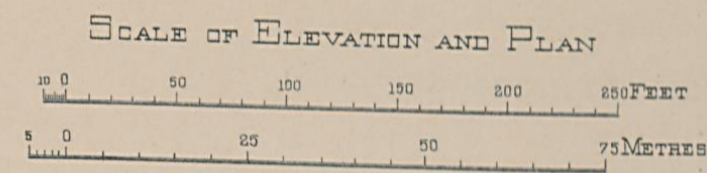
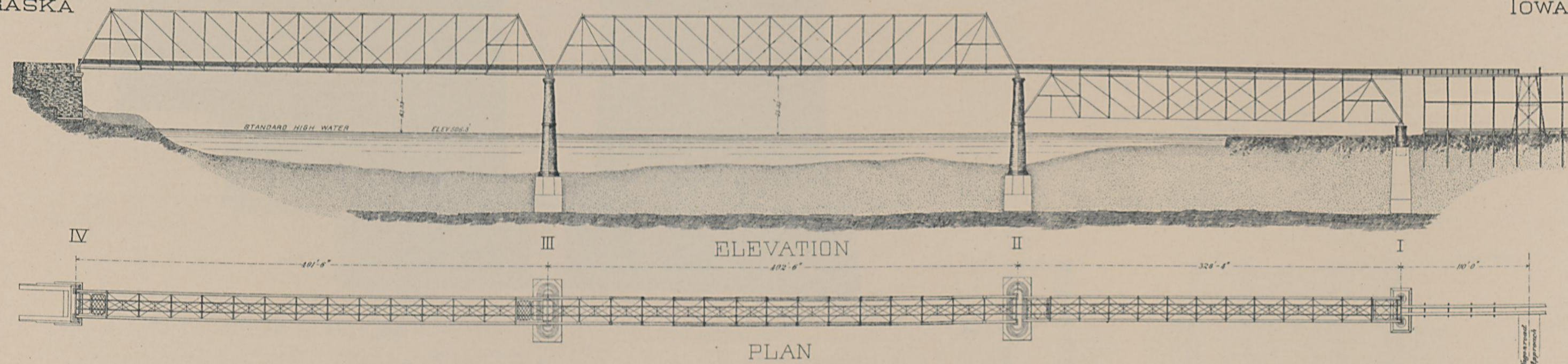

ALIGNMENT

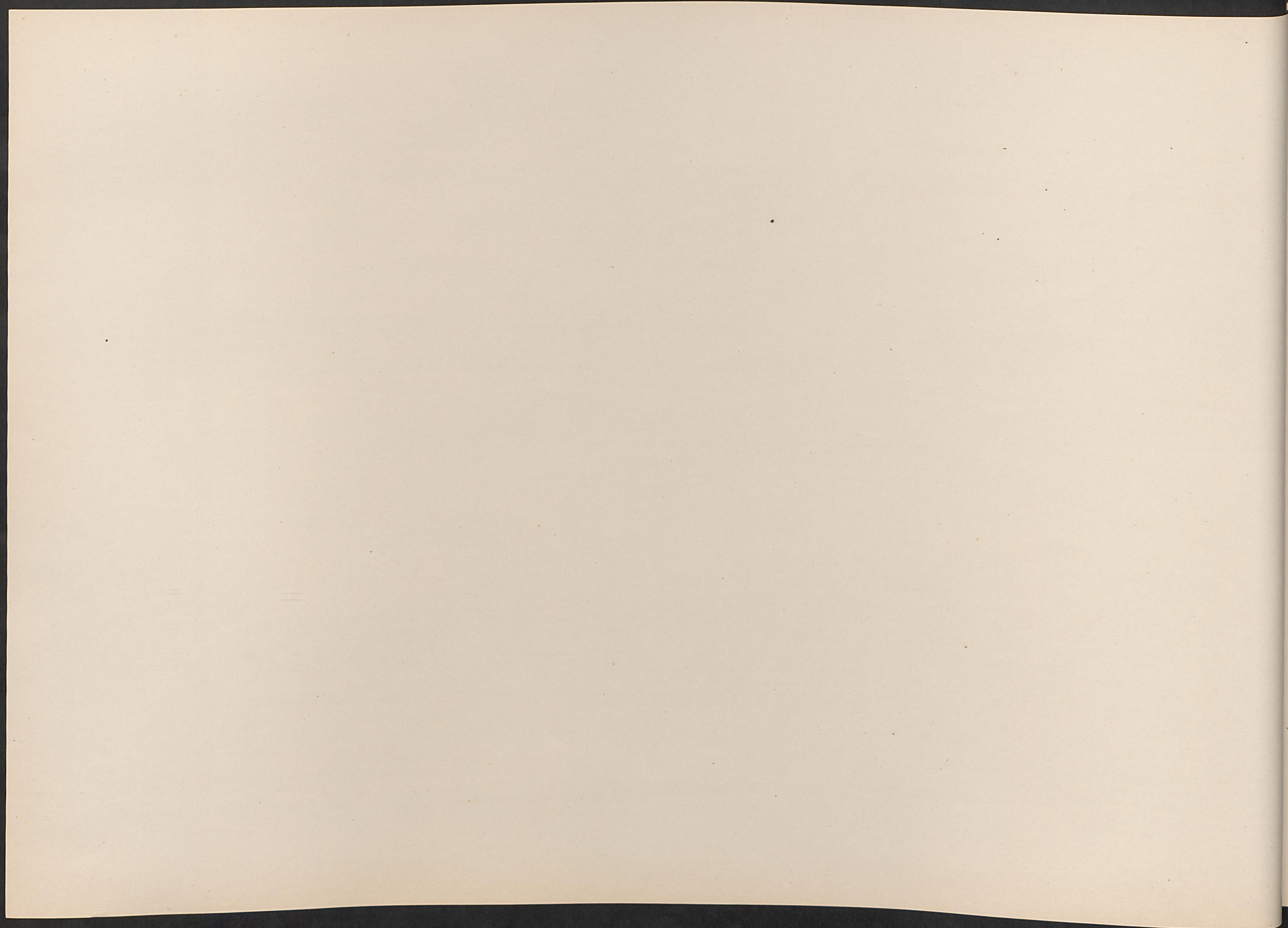

ABUTMENT  
OR PIER IV.

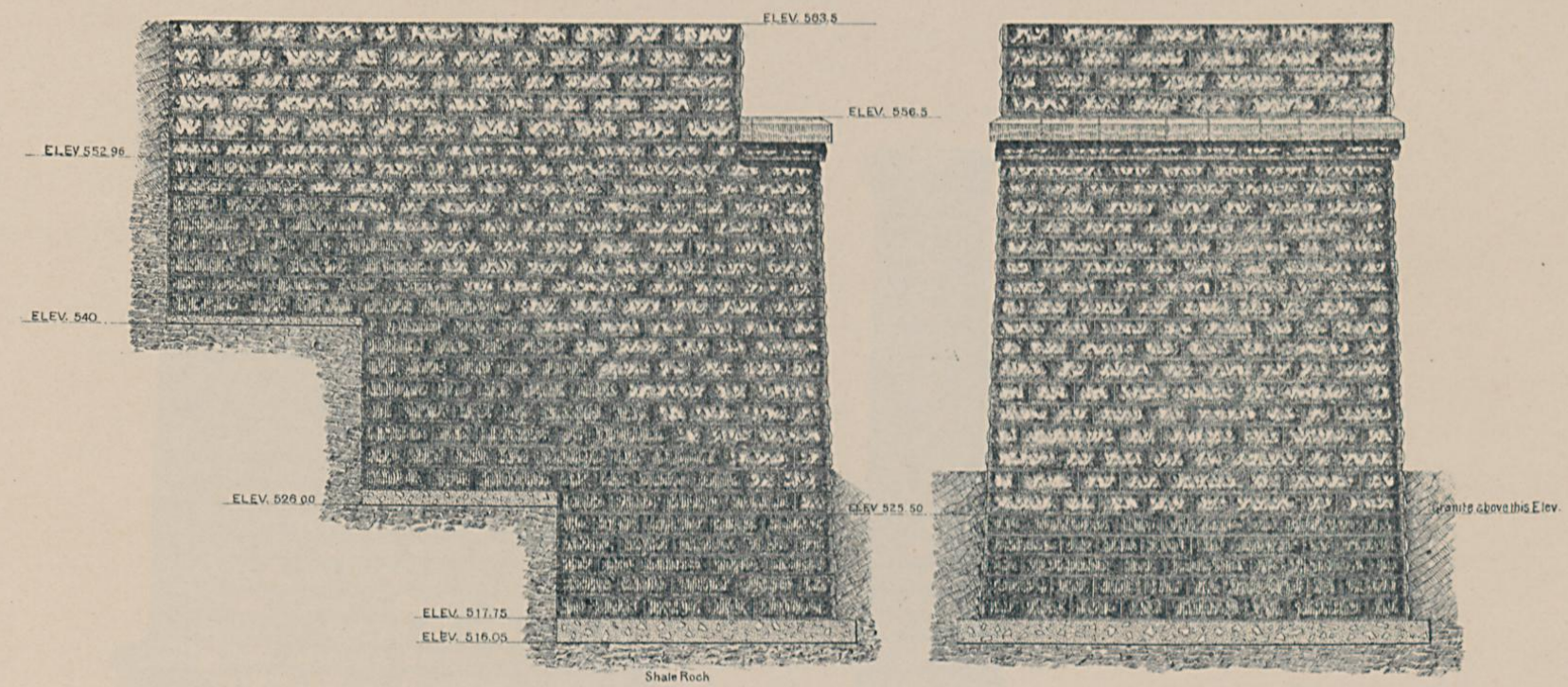

SIDE ELEVATION.

END ELEVATION.

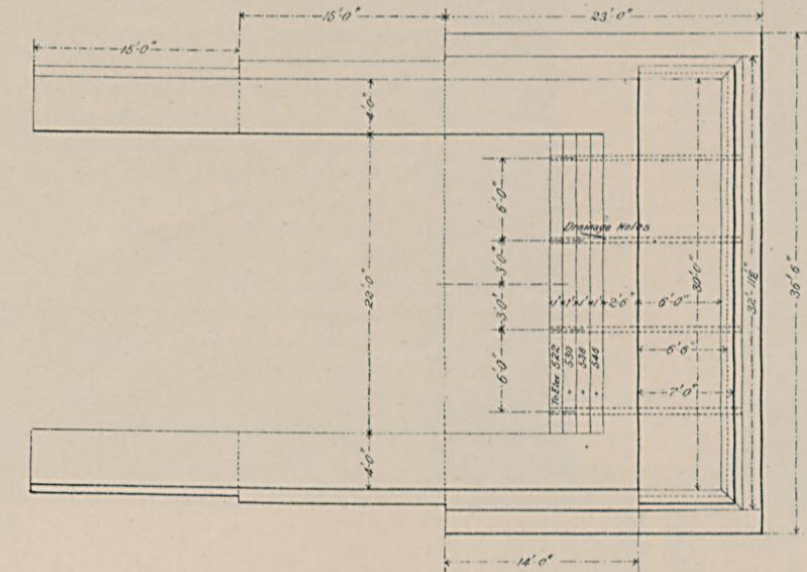

PLAN.

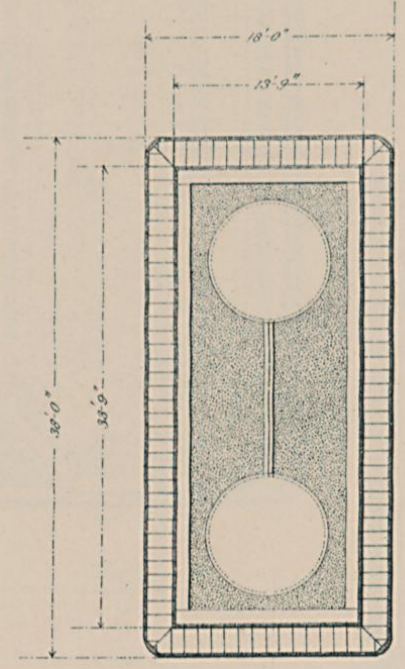

PLAN.

C. B. & Q. R. R.  
NEBRASKA CITY BRIDGE

PIER I.

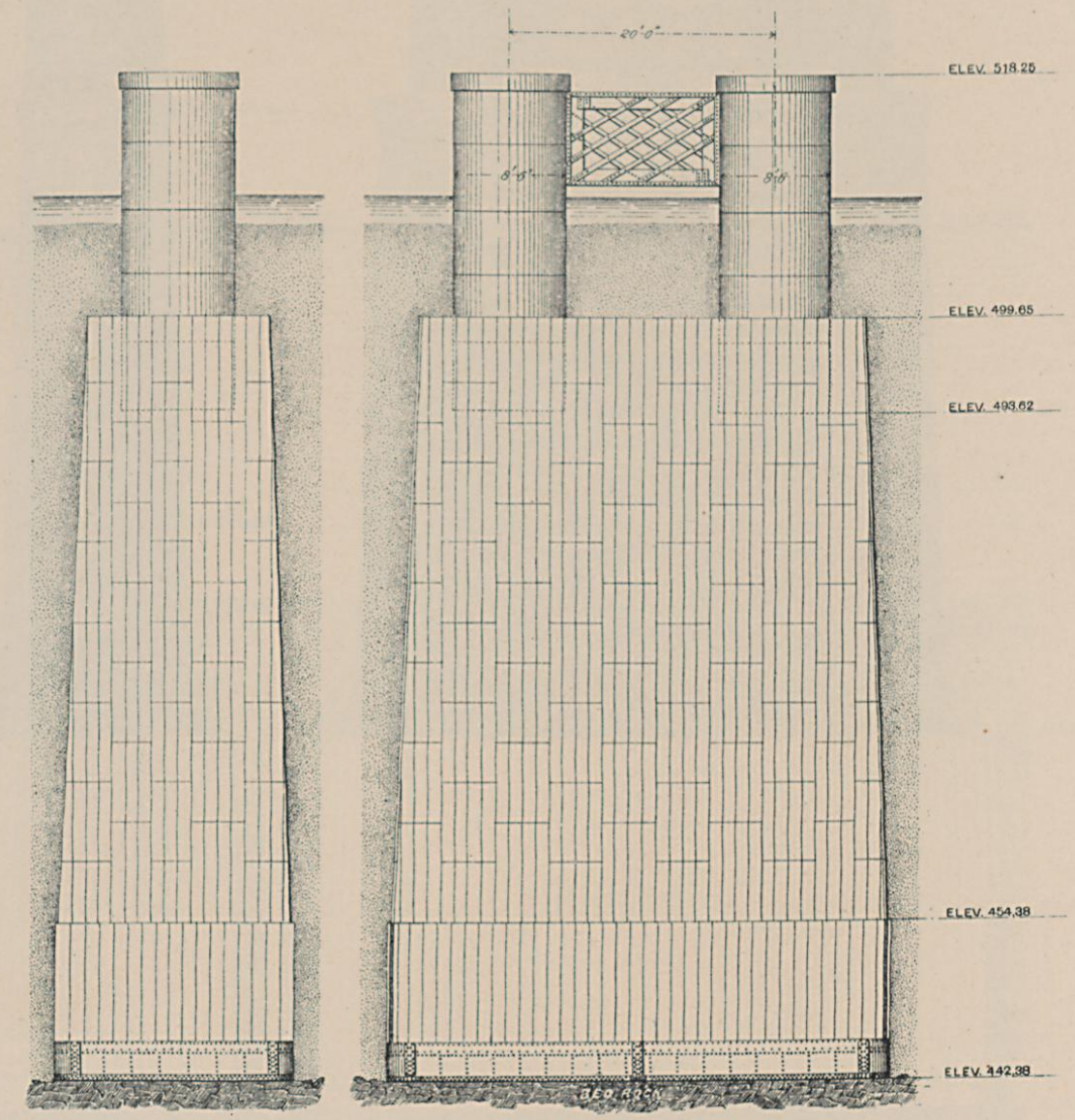

END ELEVATION.

SIDE ELEVATION.

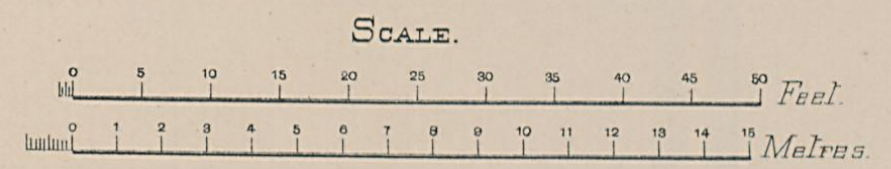

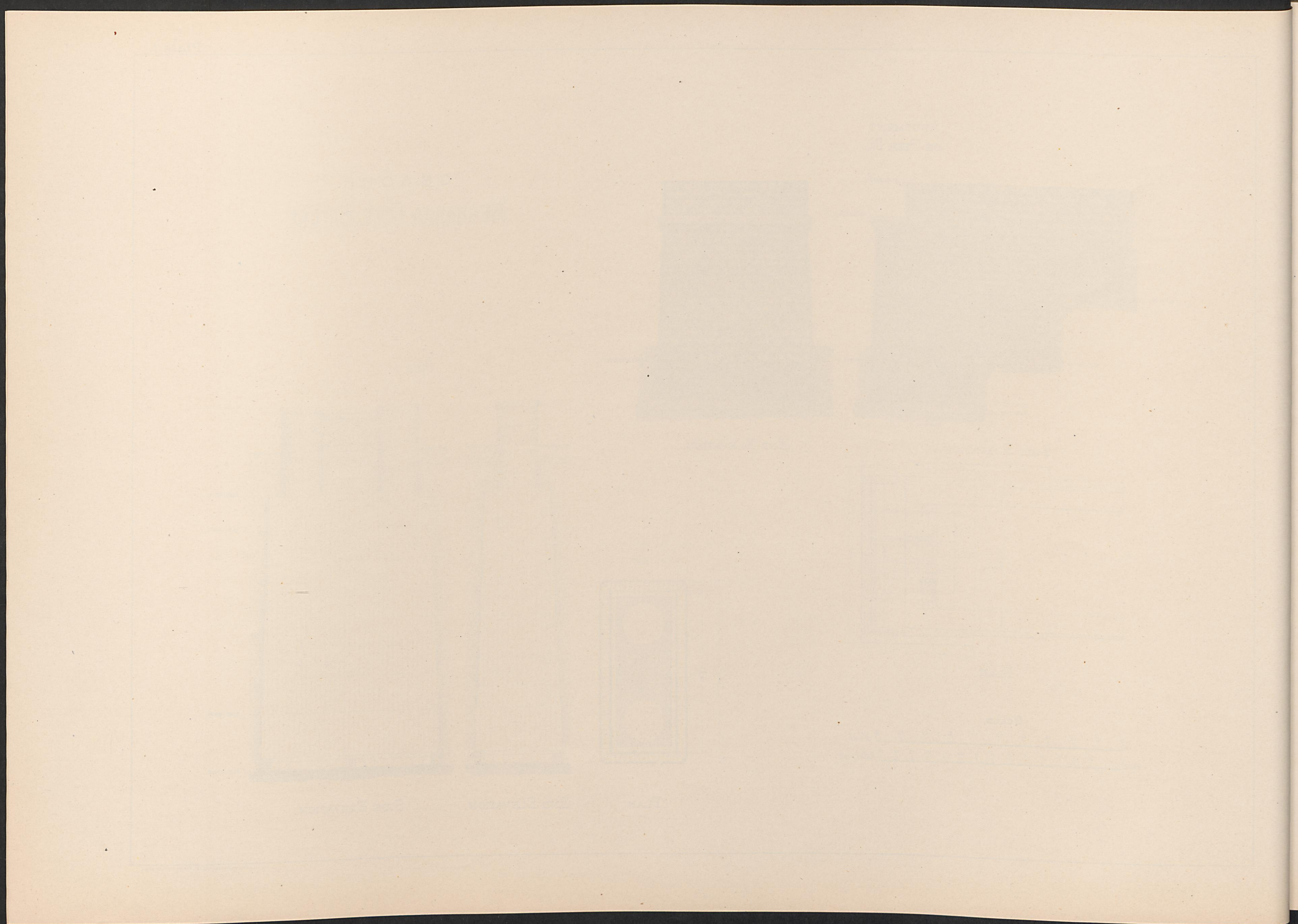

C. B. & Q. R. R.  
NEBRASKA CITY BRIDGE

PIER III.

PIER II.

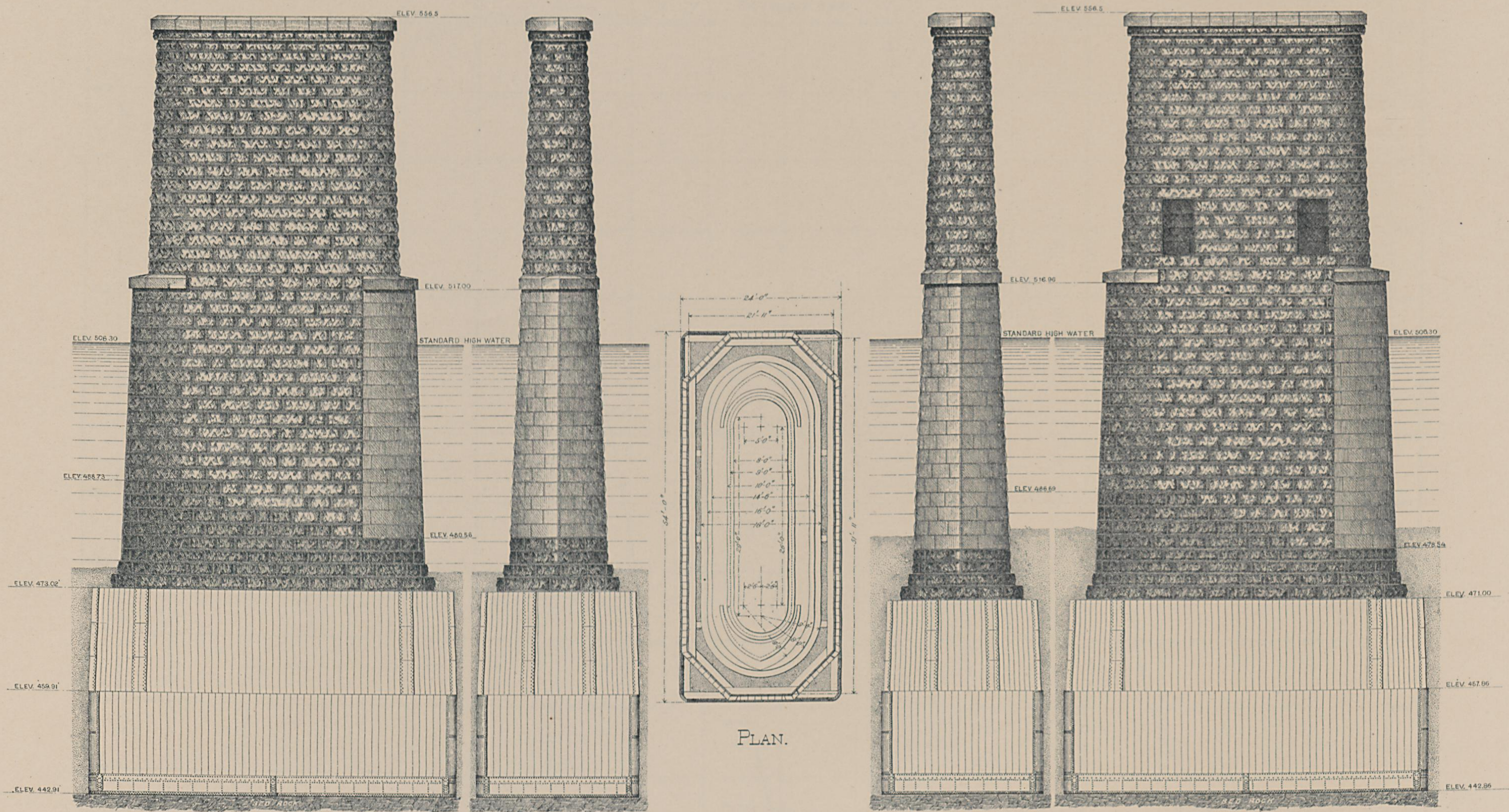

SIDE ELEVATION.

END ELEVATION.

END ELEVATION.

SIDE ELEVATION.

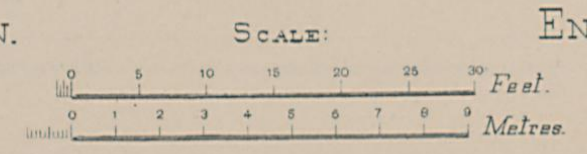

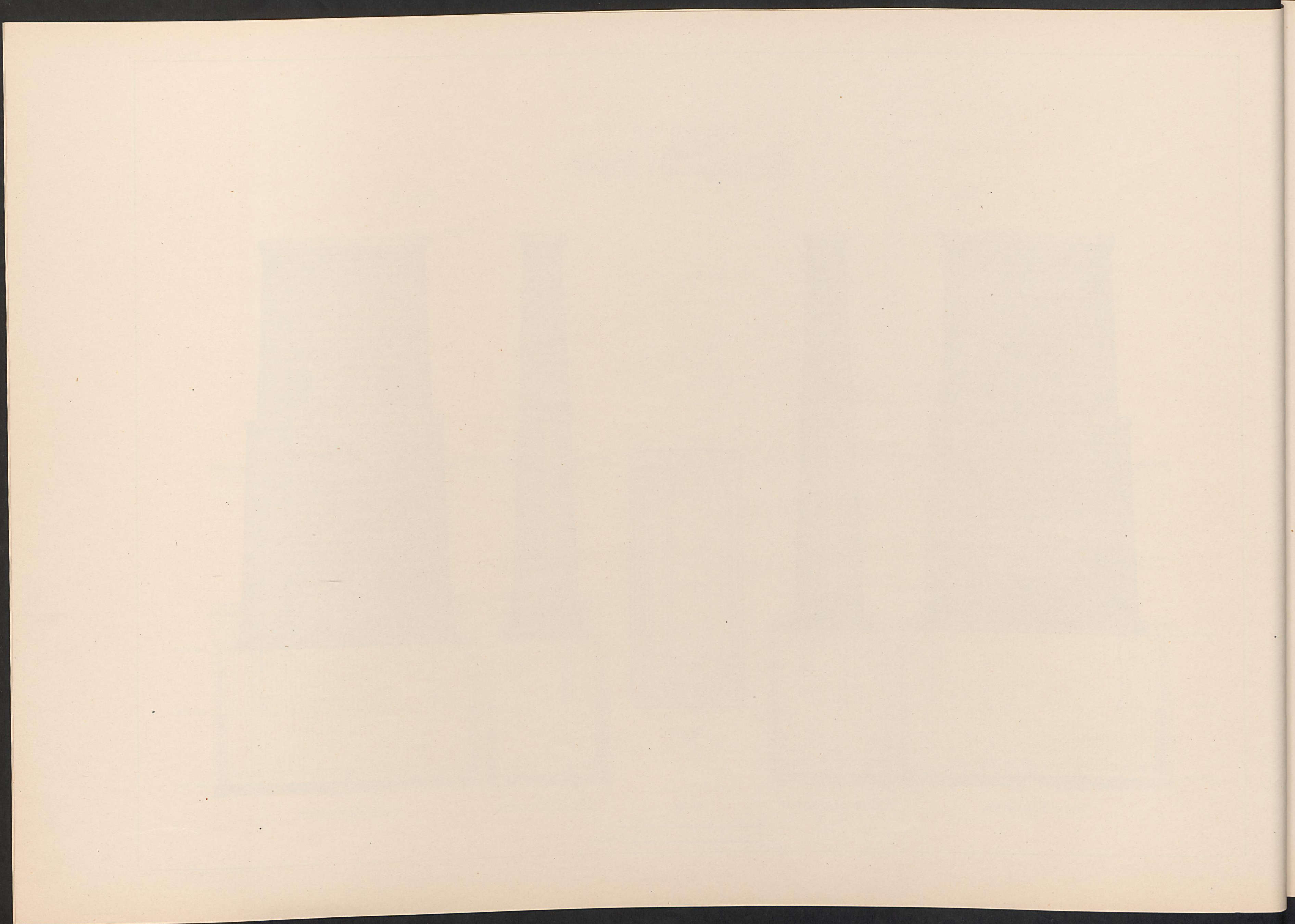

C. B. & Q. R. R.  
NEBRASKA CITY BRIDGE

DIAGRAM SHOWING RATE OF PROGRESS IN SINKING CAISSONS

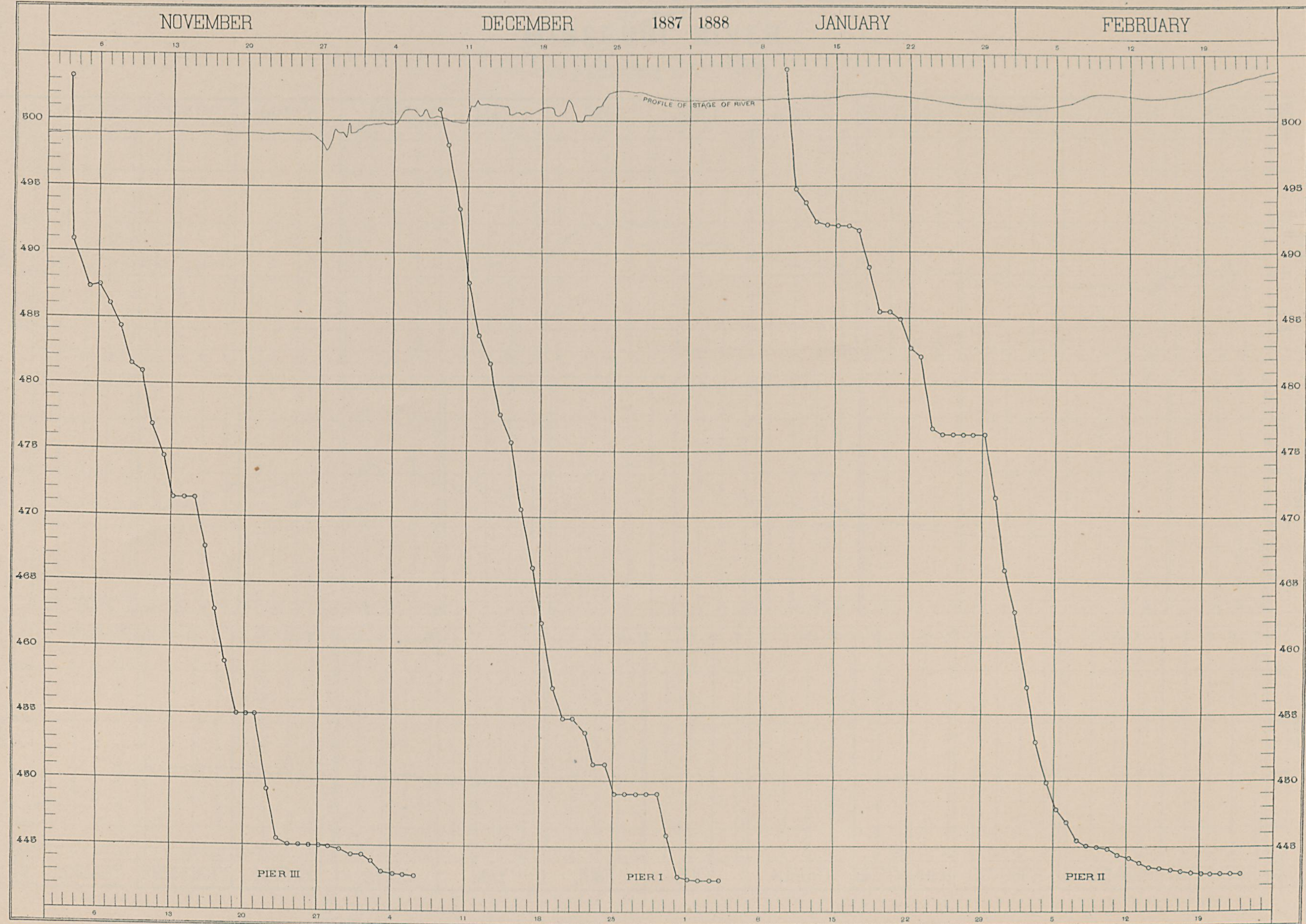

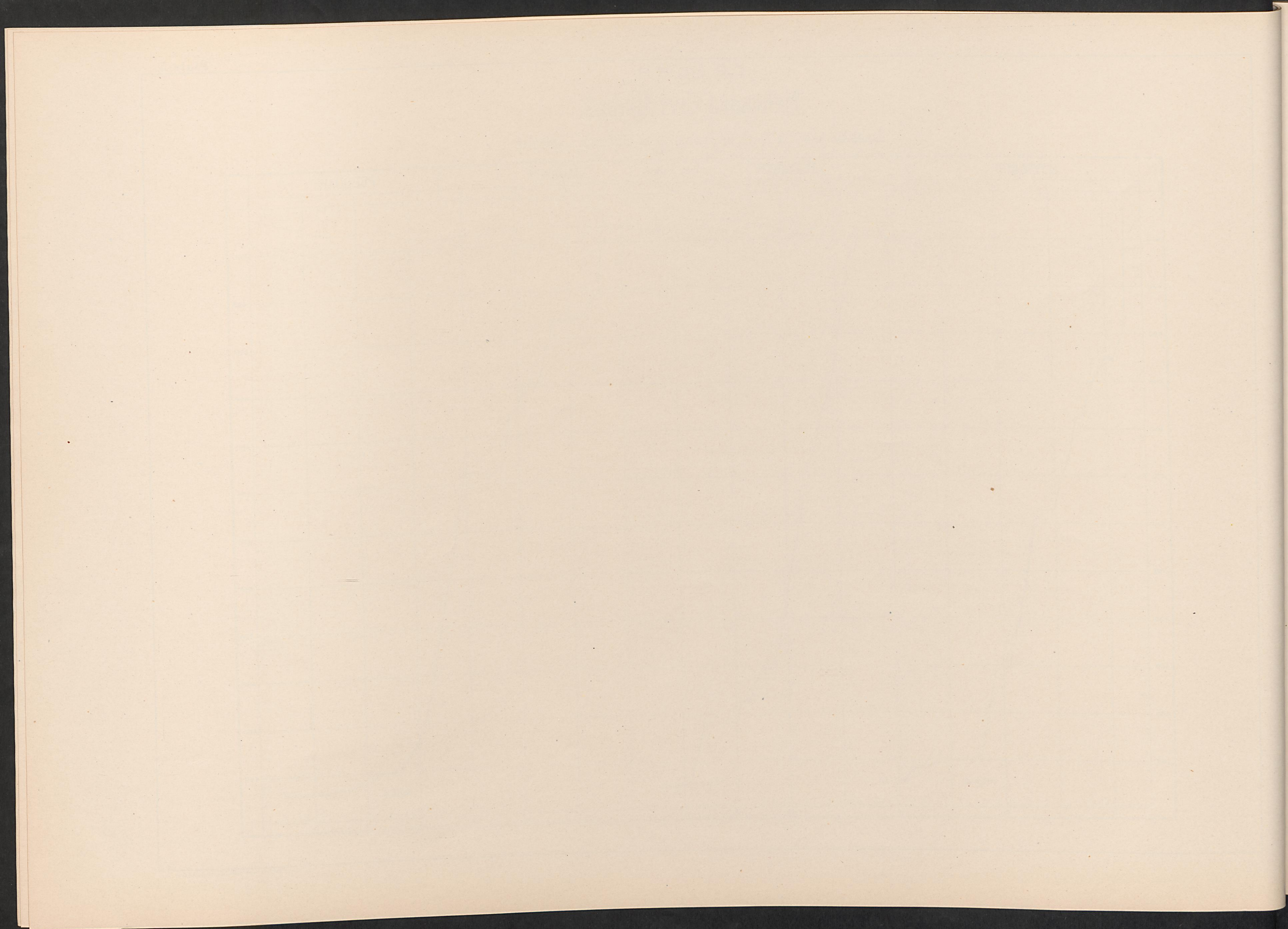

C. B. & Q. R. R.  
NEBRASKA CITY BRIDGE  
RECORD OF WATER STAGE  
OF THE  
MISSOURI RIVER  
AT NEBRASKA CITY, NEB.

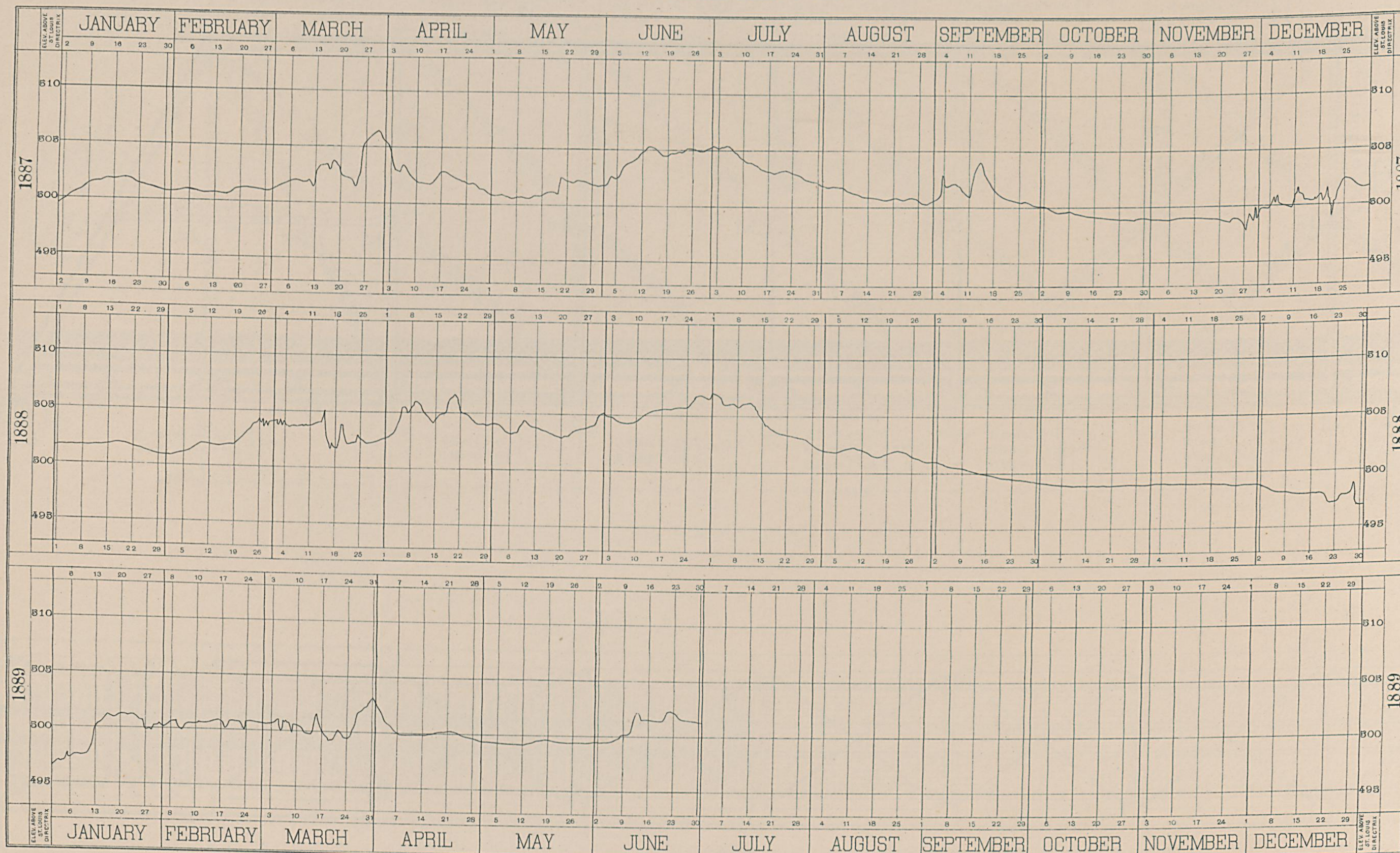

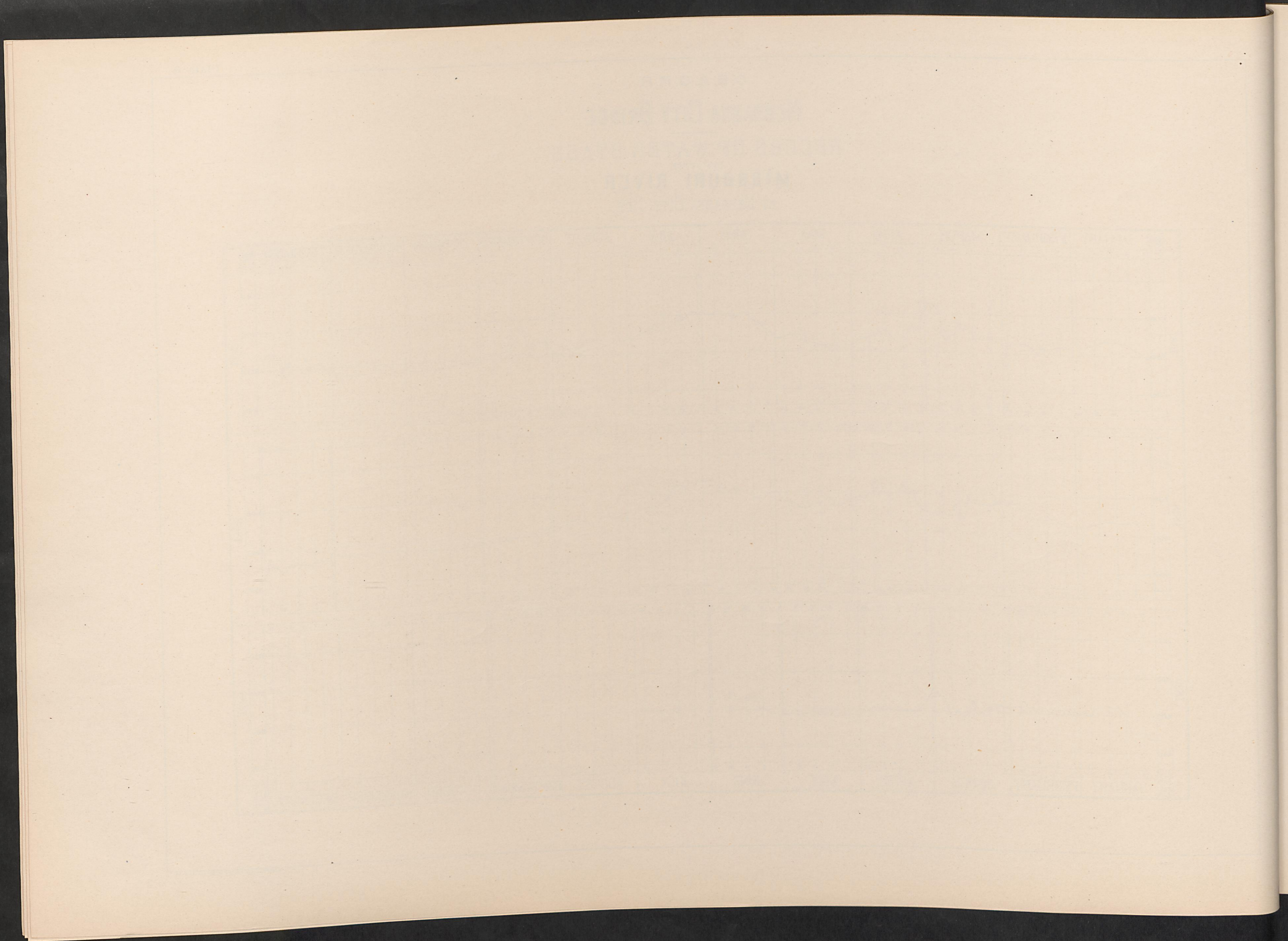

C. B. & Q. R. R.  
**NEBRASKA CITY BRIDGE**  
 THROUGH SPAN - 400 FT 0 IN C. TO C. END PINS

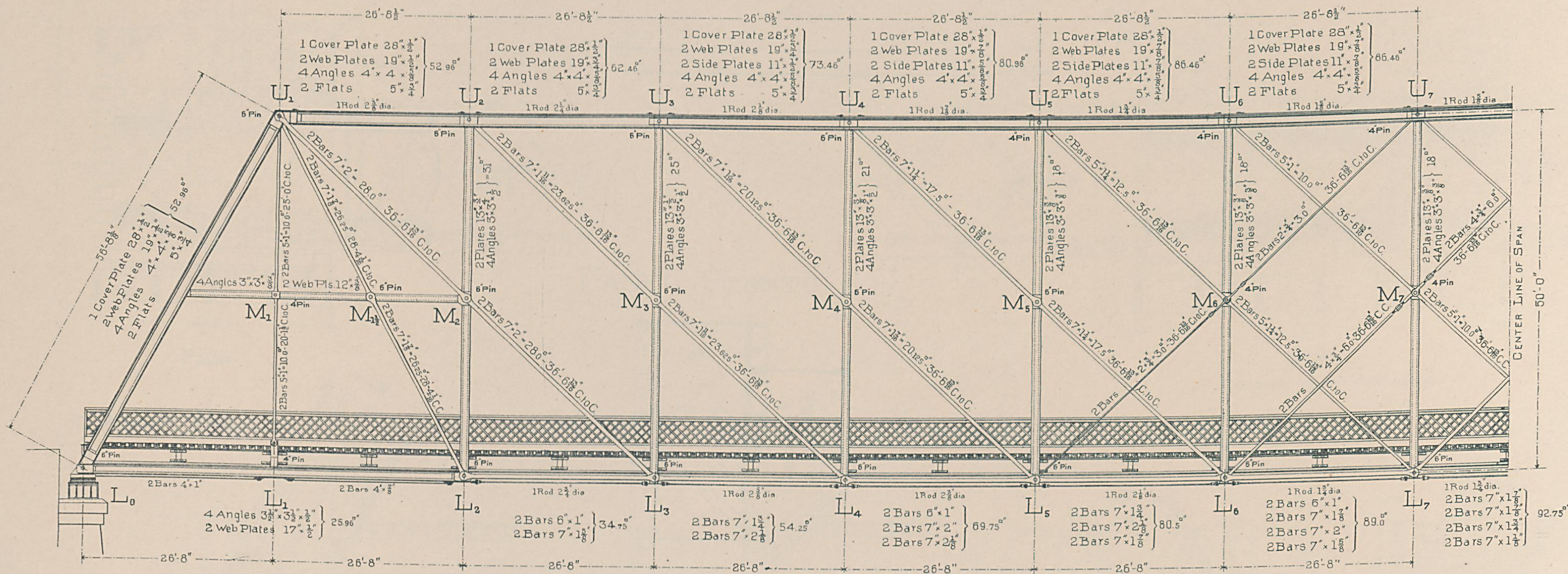

ELEVATION

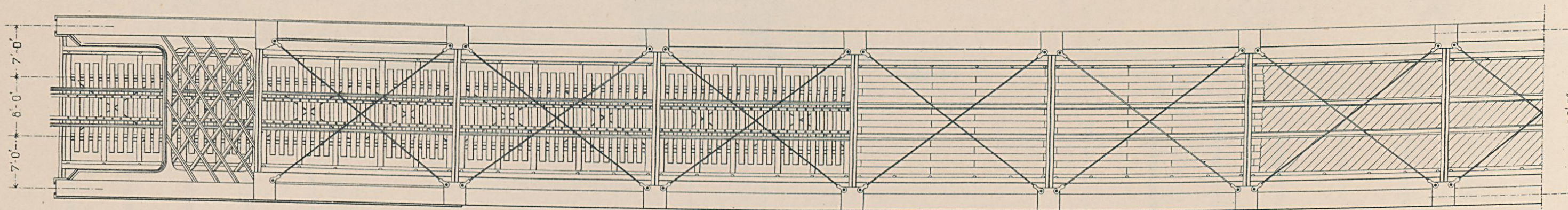

PLAN

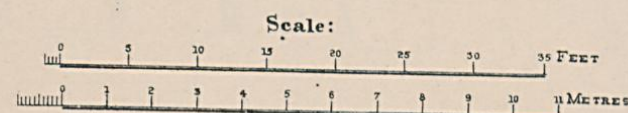

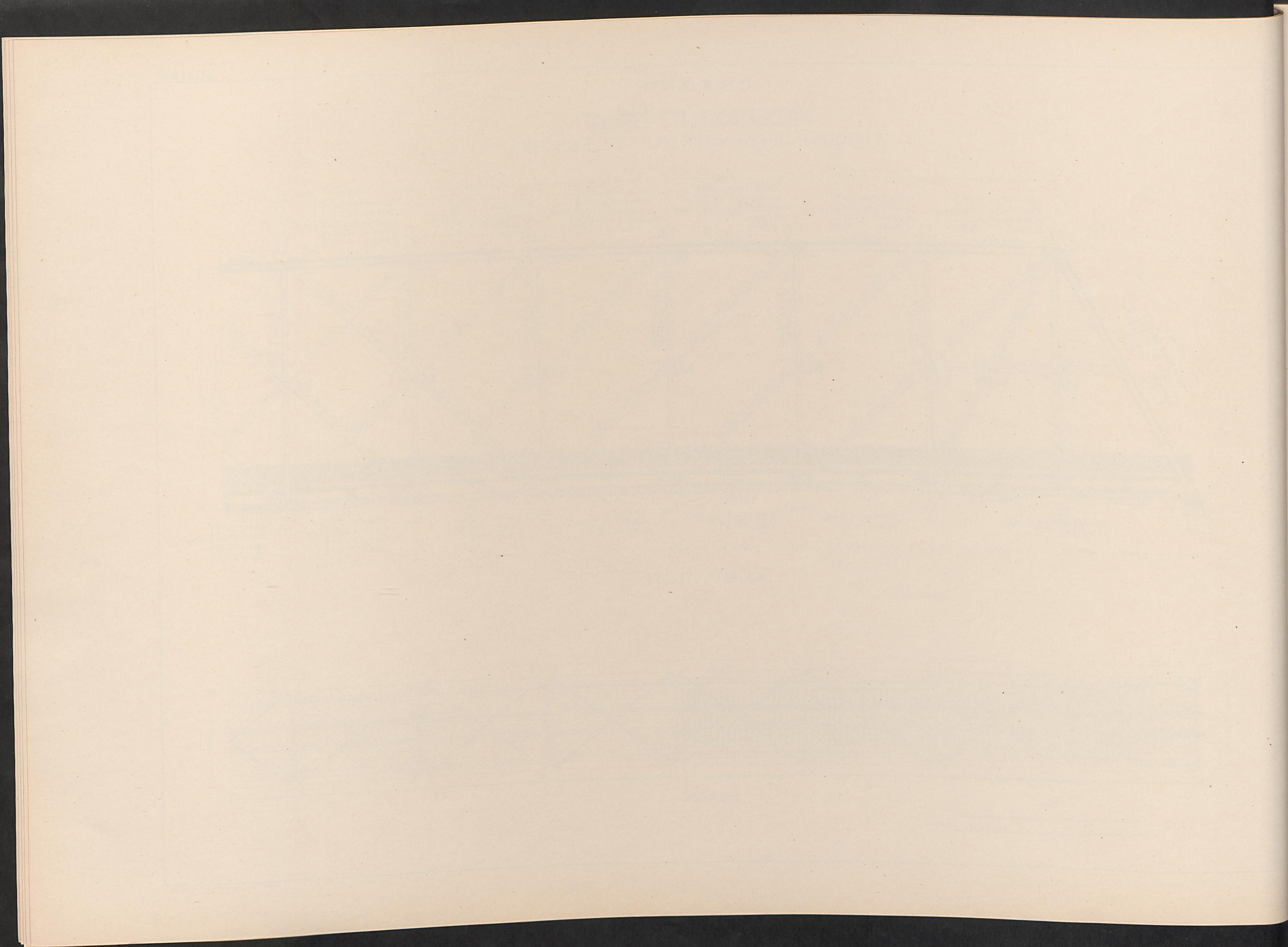

C.B. & Q.R.R.  
NEBRASKA CITY BRIDGE  
THROUGH SPAN 400<sup>FT</sup> 0<sup>IN</sup> C. TO C. END PINS.

Scale:

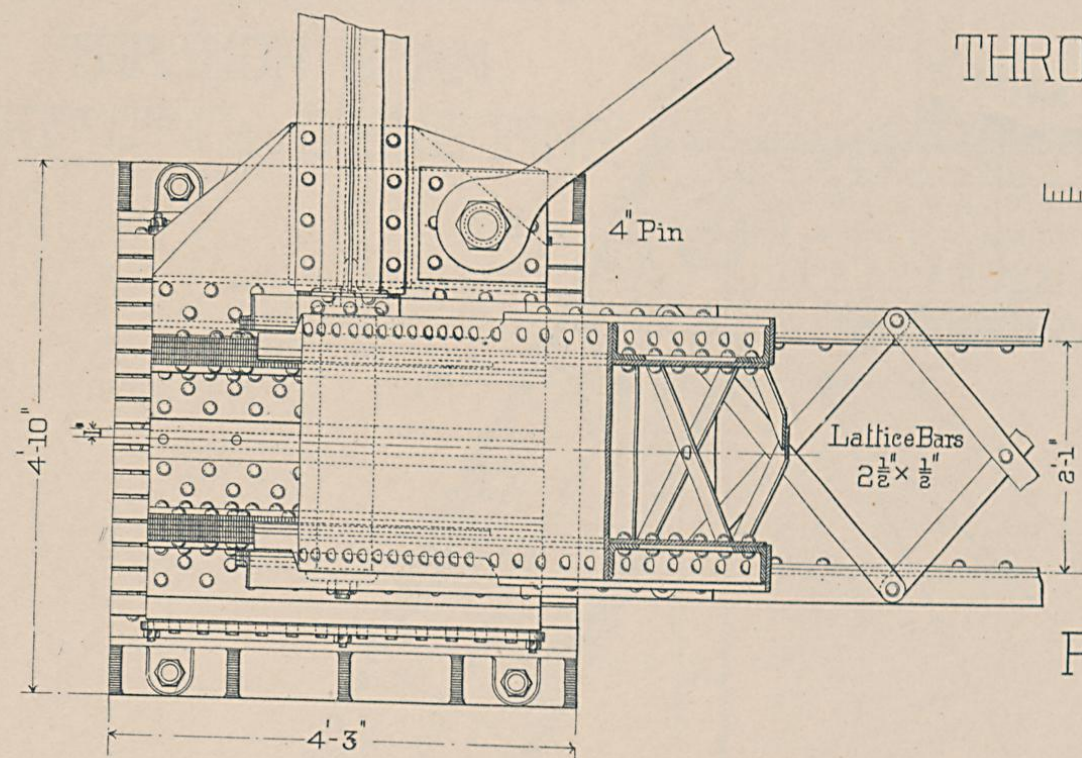
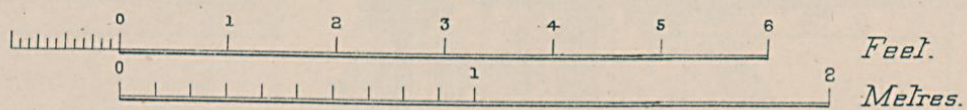

PLAN.

EXPANSION END.

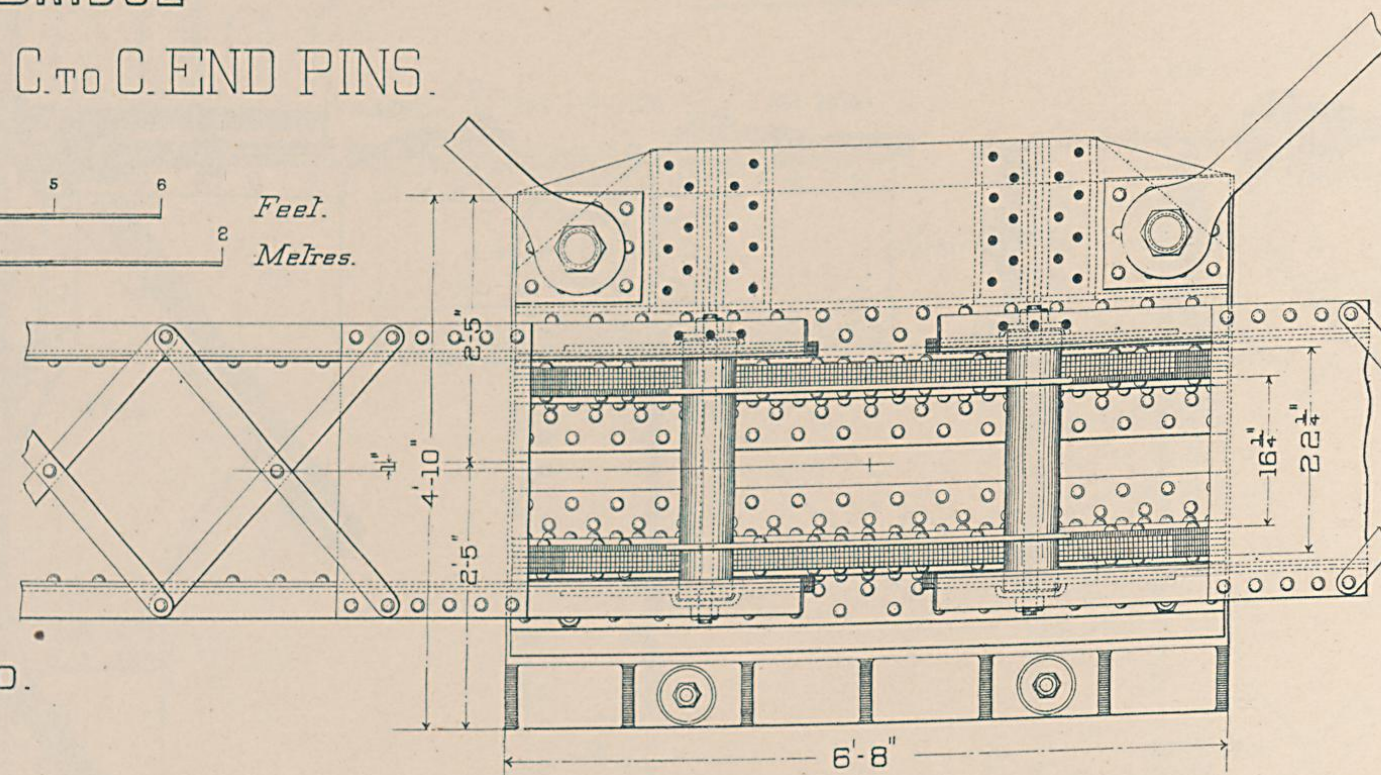

PLAN.

Floorbeams and End Posts removed.

FIXED END.

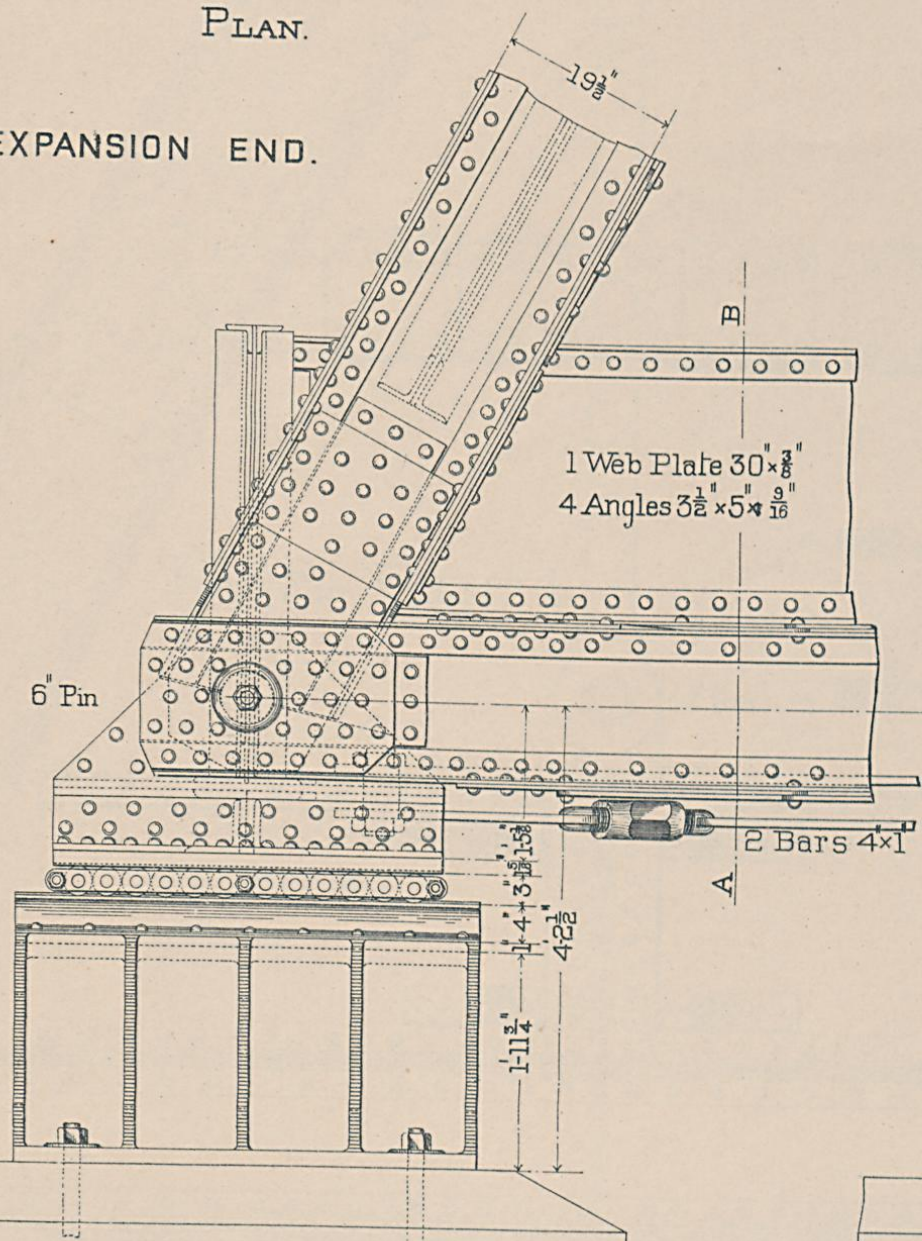

SIDE ELEVATION AT WEST ABUTMENT.

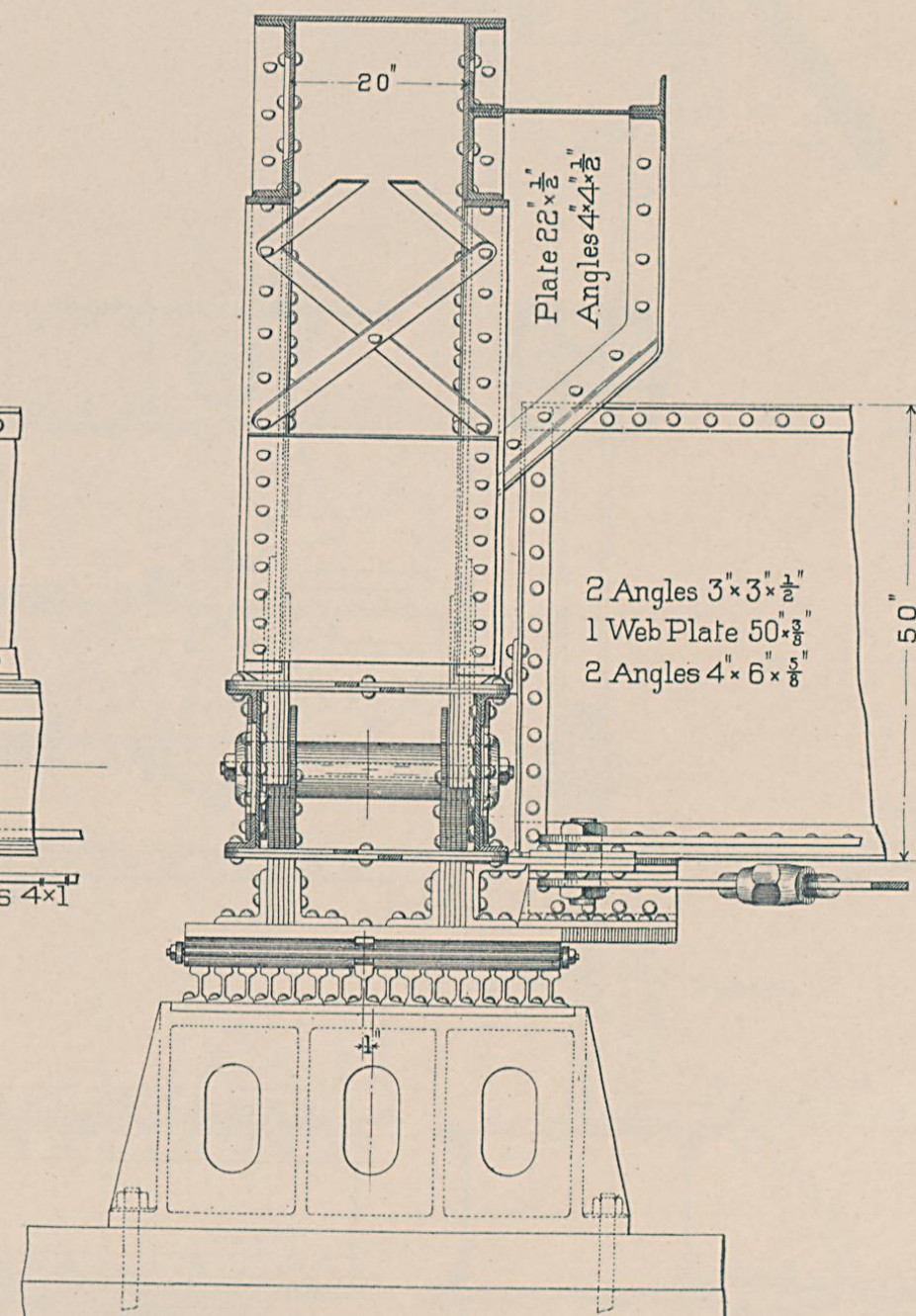

SECTION AB.

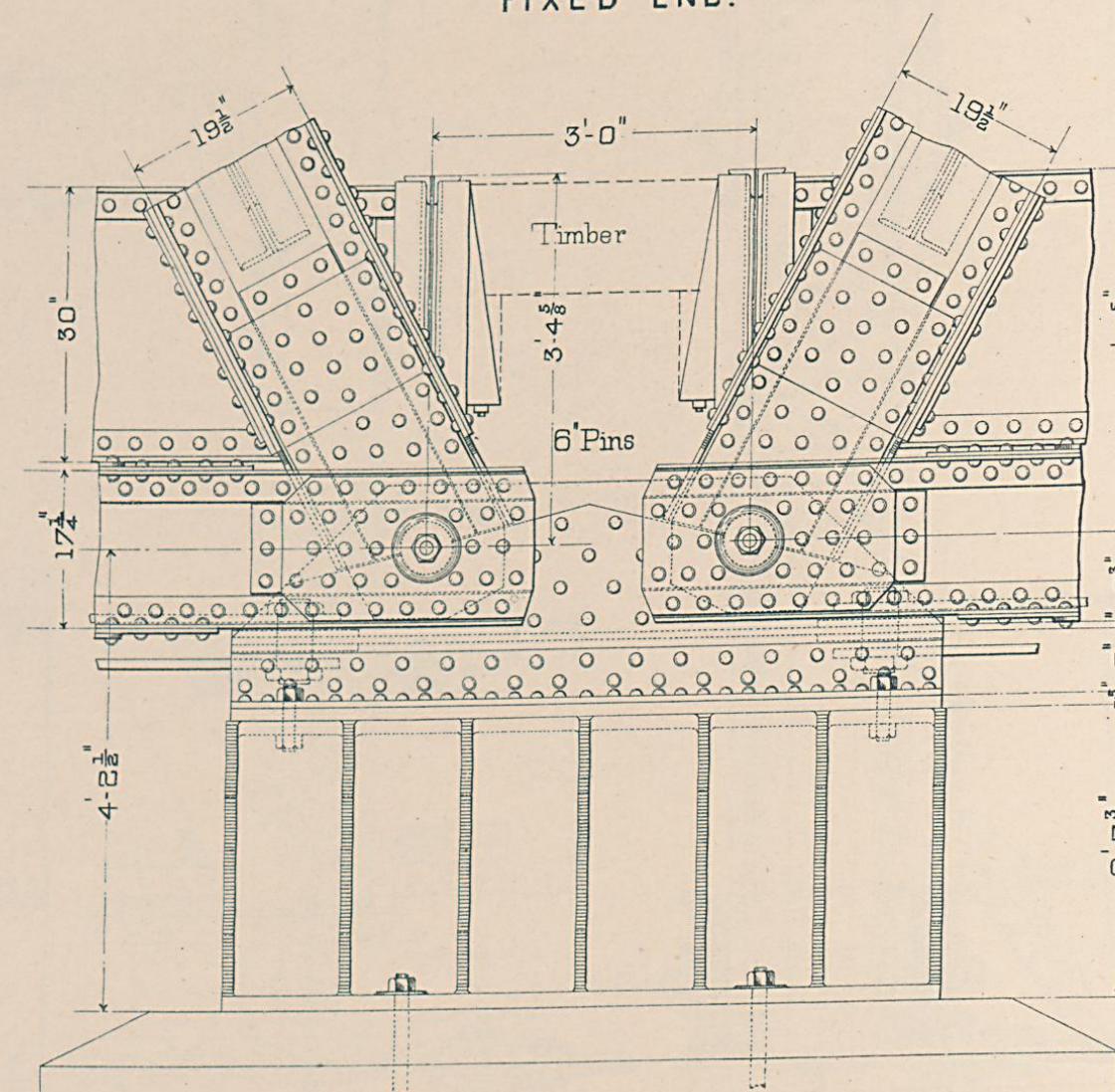

SIDE ELEVATION AT PIER III.

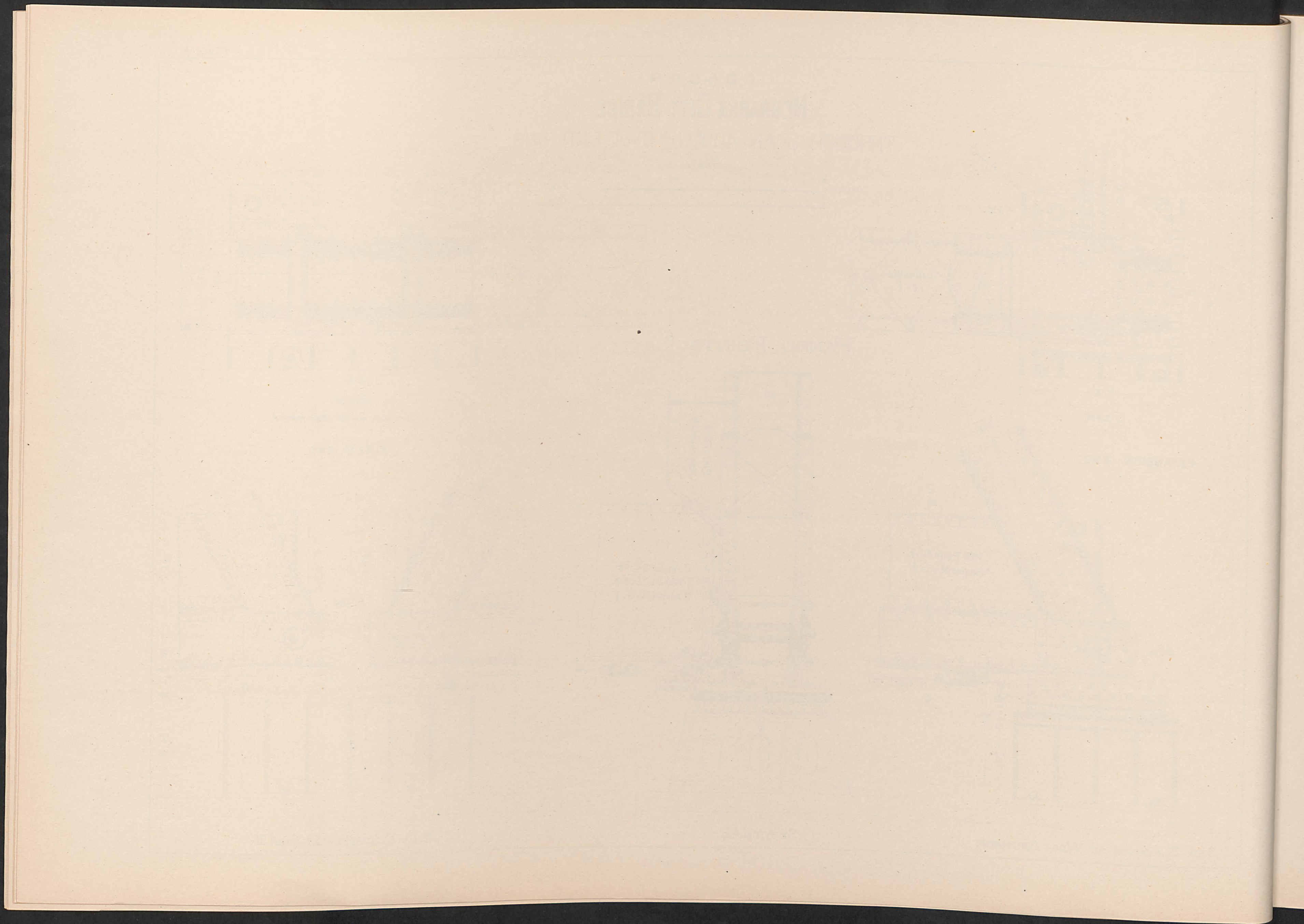

C. B. & Q. R. R.  
NEBRASKA CITY BRIDGE  
THROUGH SPAN  
400 FT 0 IN C. TO C. END PINS.

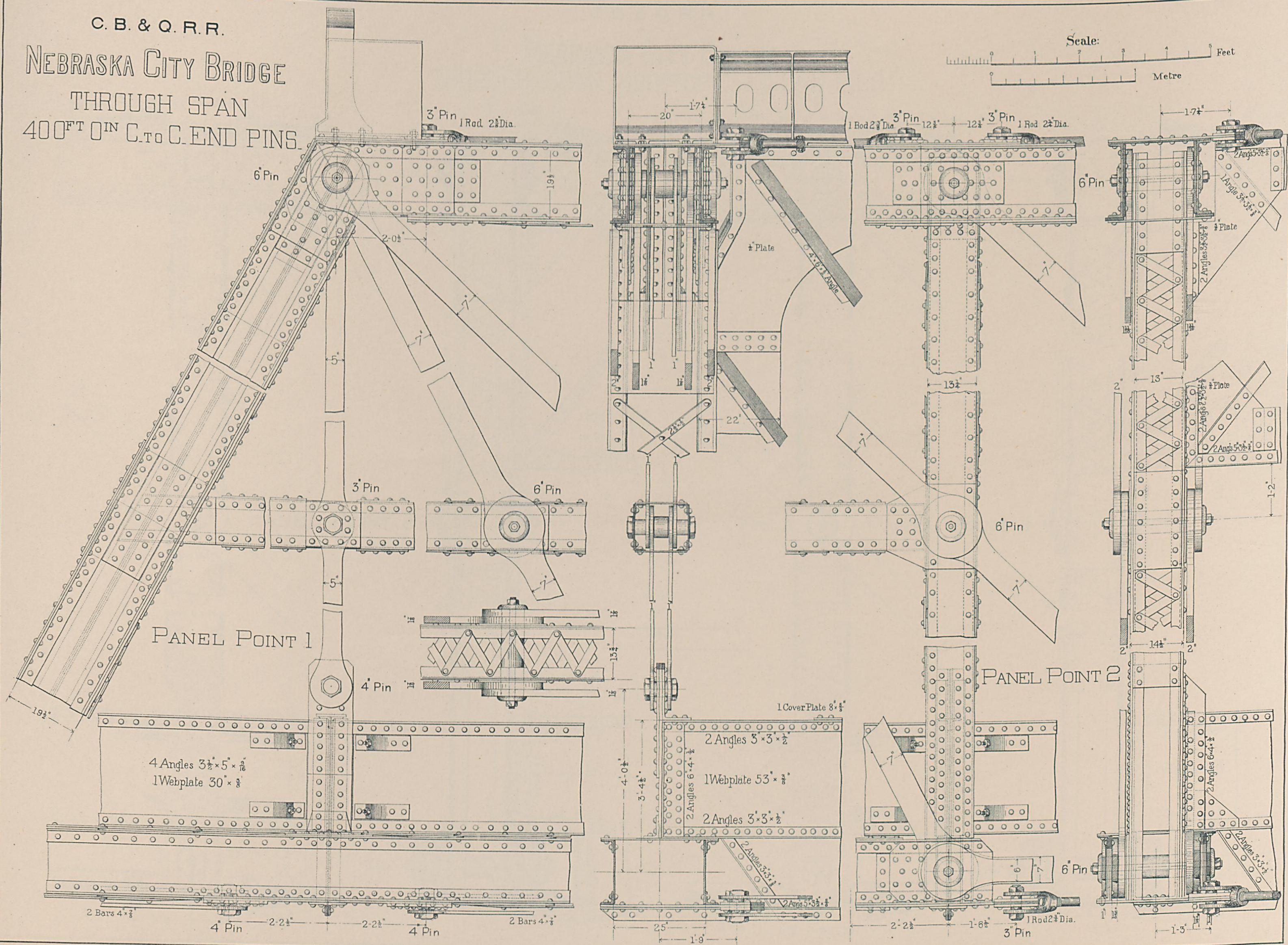

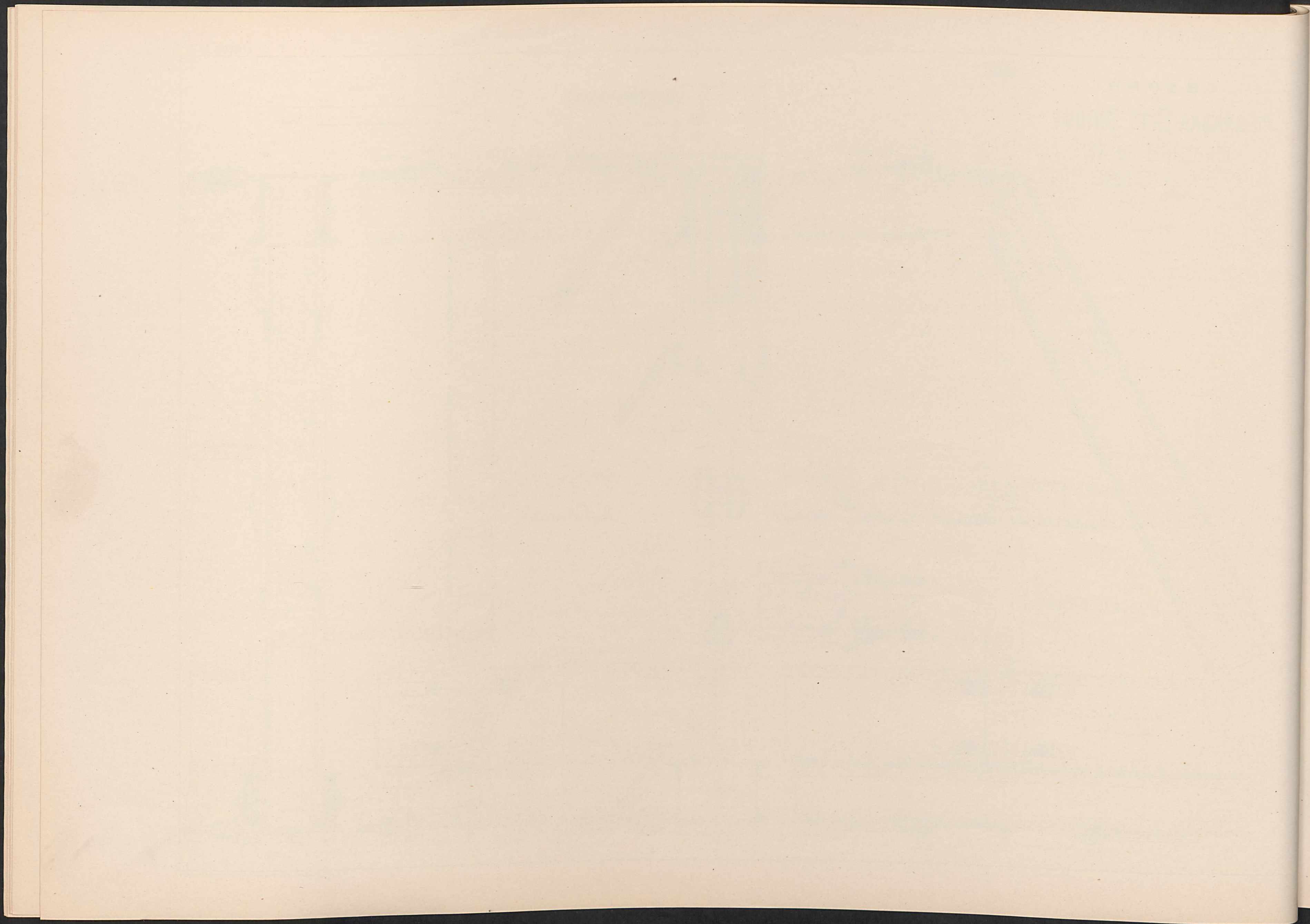

C. B. & Q. R. R.

# NEBRASKA CITY BRIDGE THROUGH SPAN, 400 FT 0 IN C TO C. END PINS.

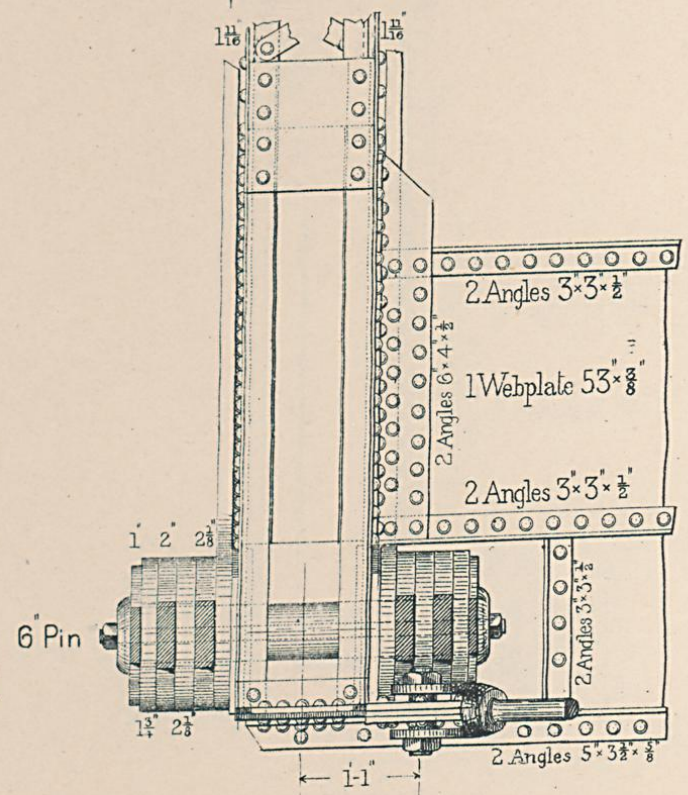
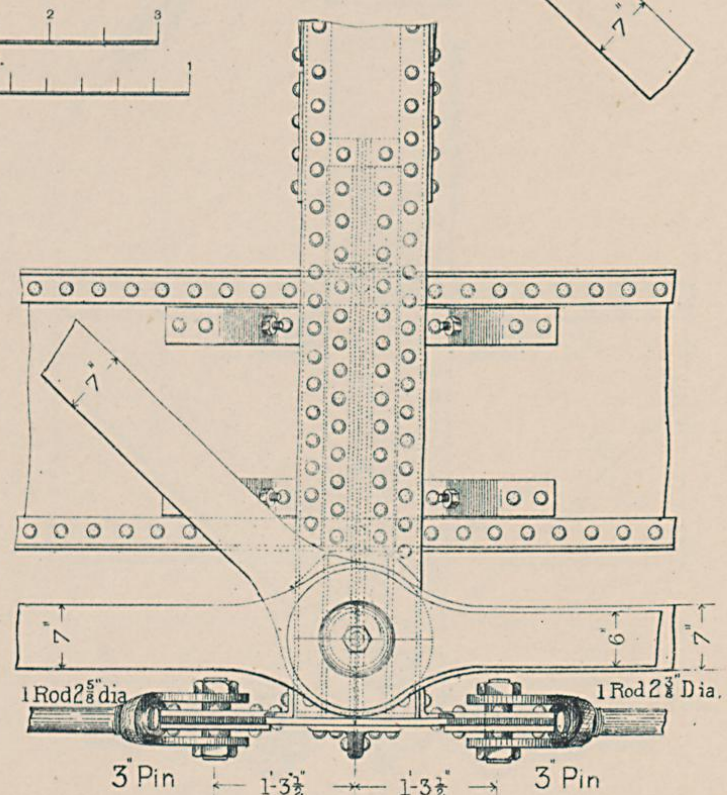
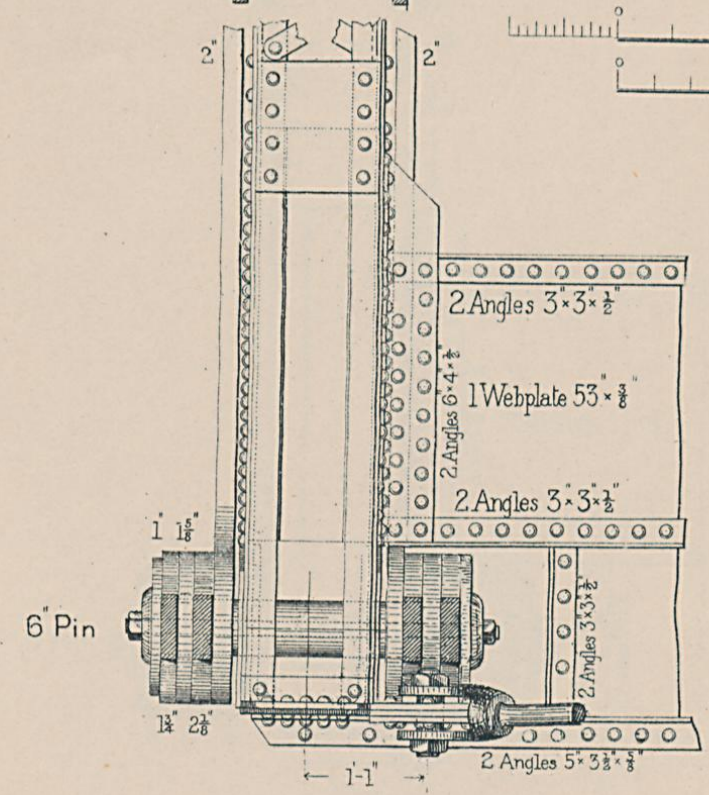
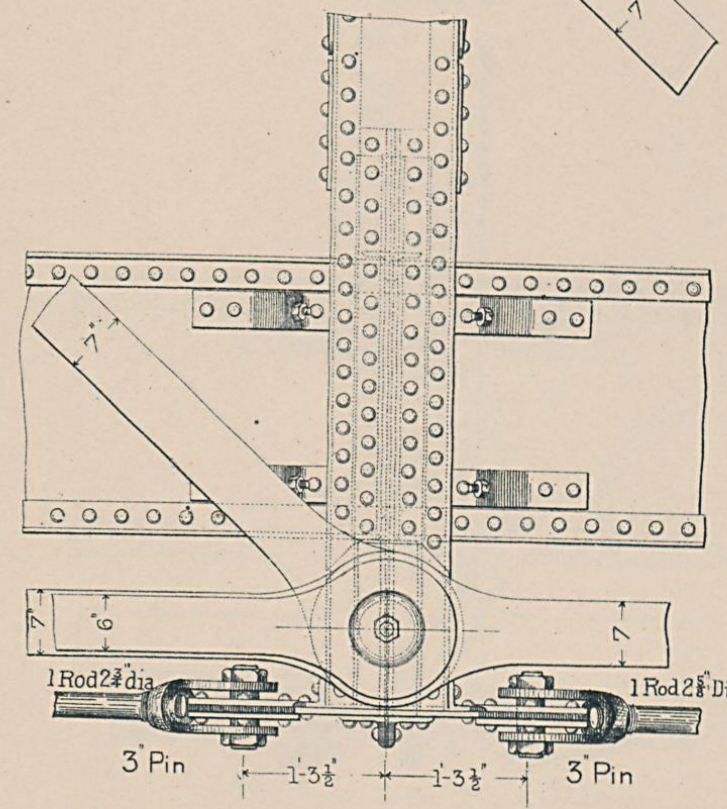
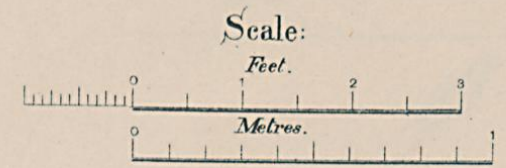
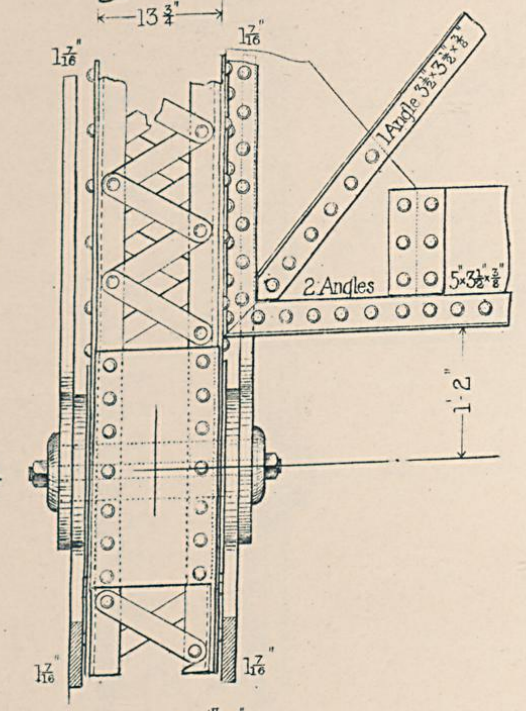
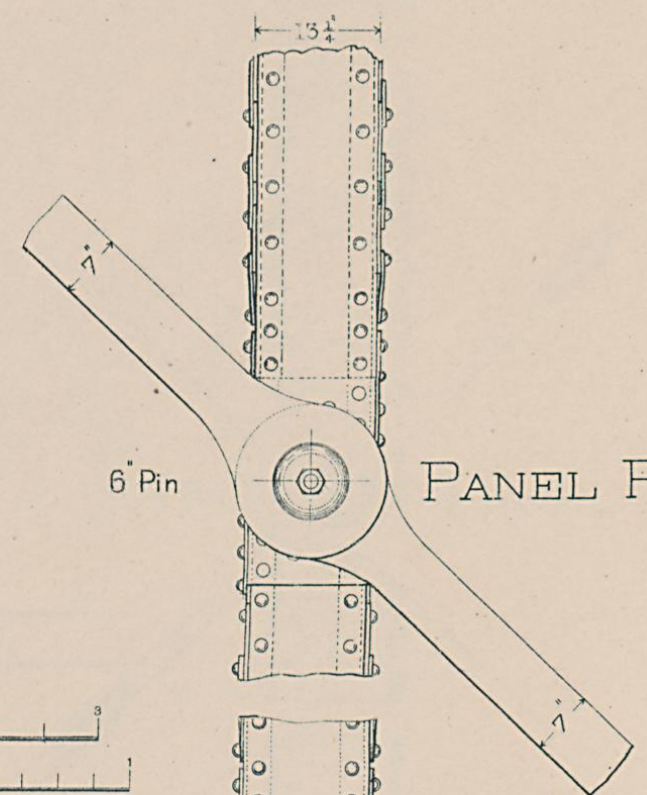
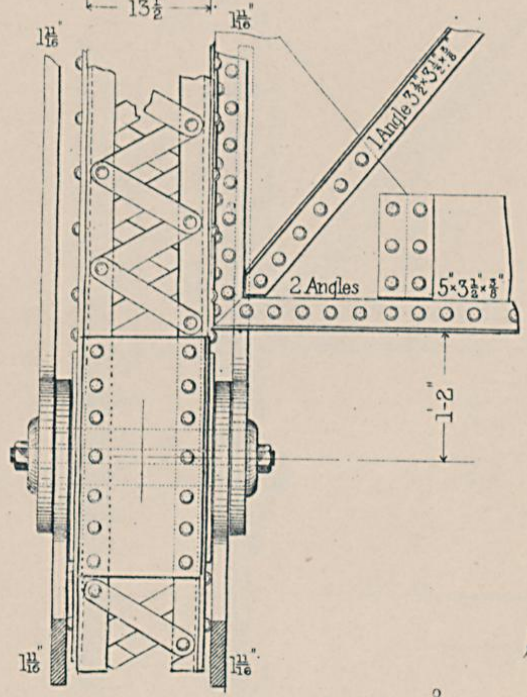
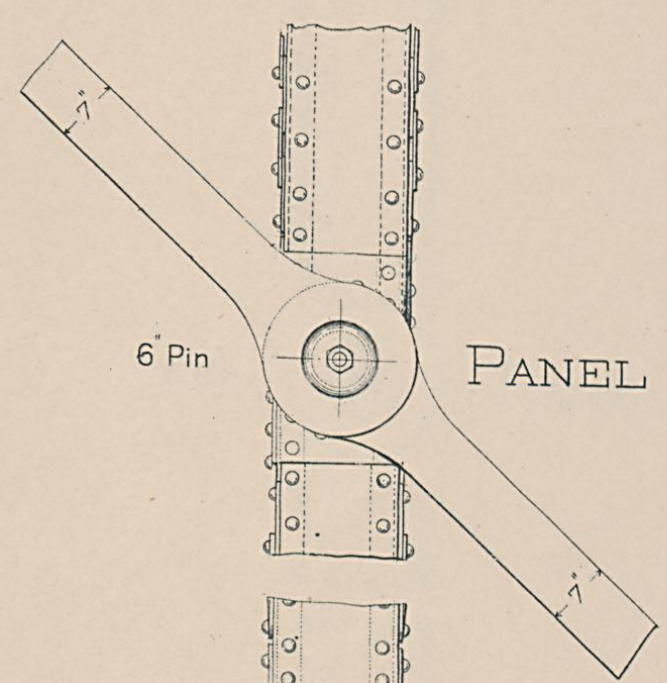
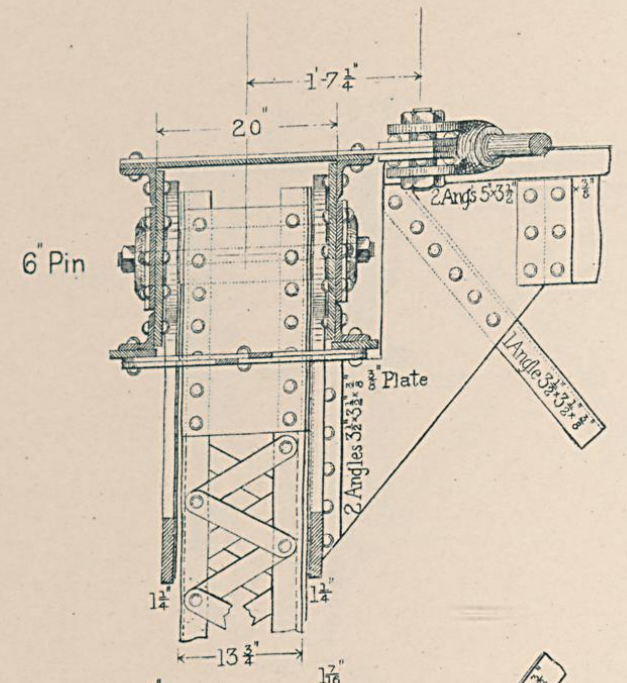
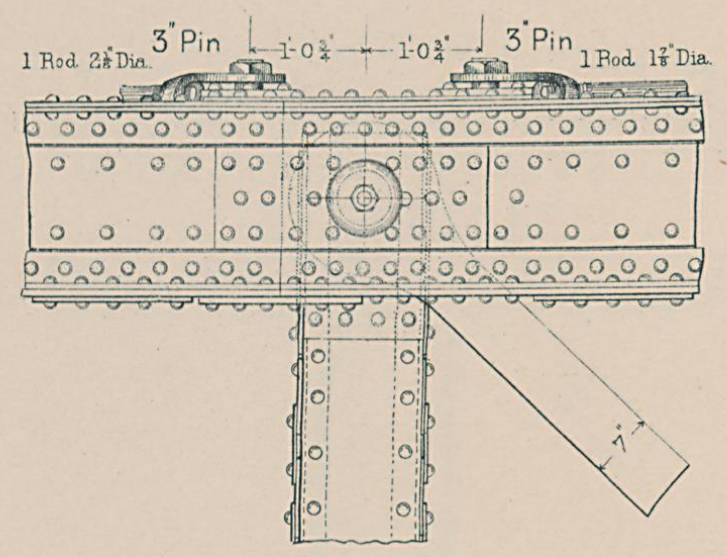
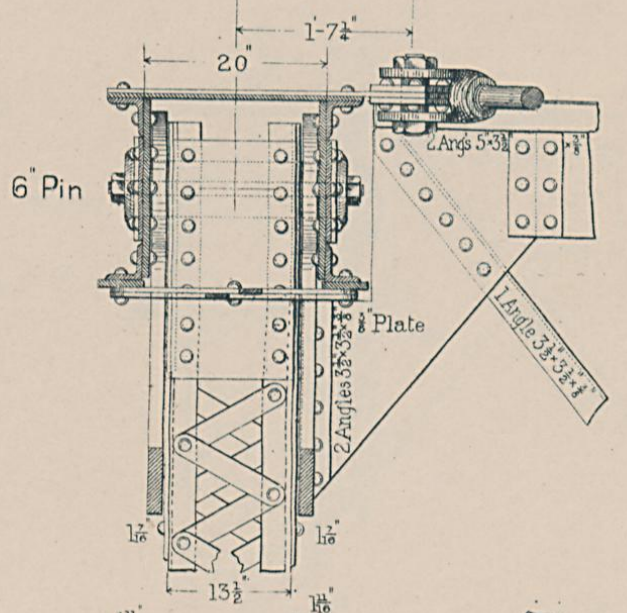
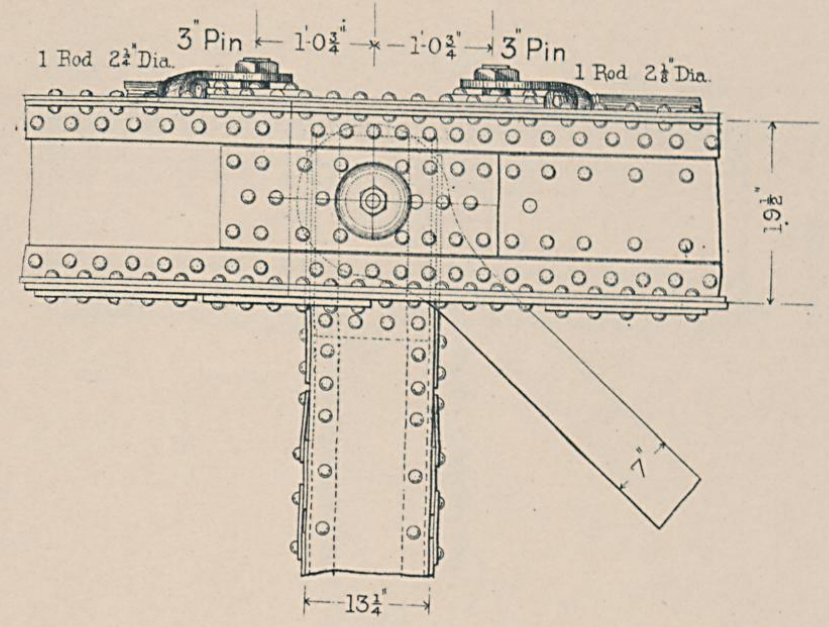

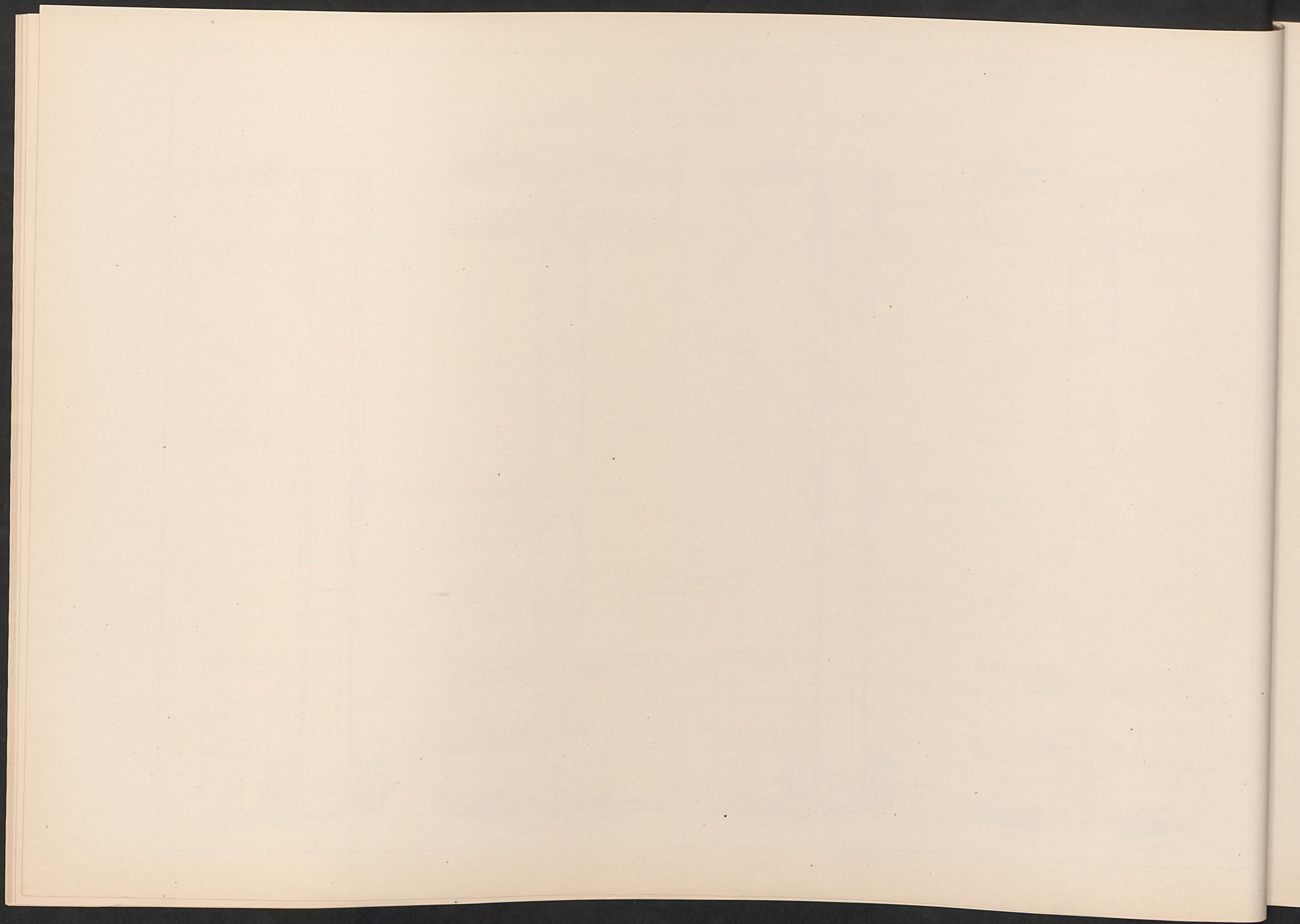

C. B. & Q. R. R.

# NEBRASKA CITY BRIDGE

THROUGH SPAN 400' 0" C. TO C. END PINS.

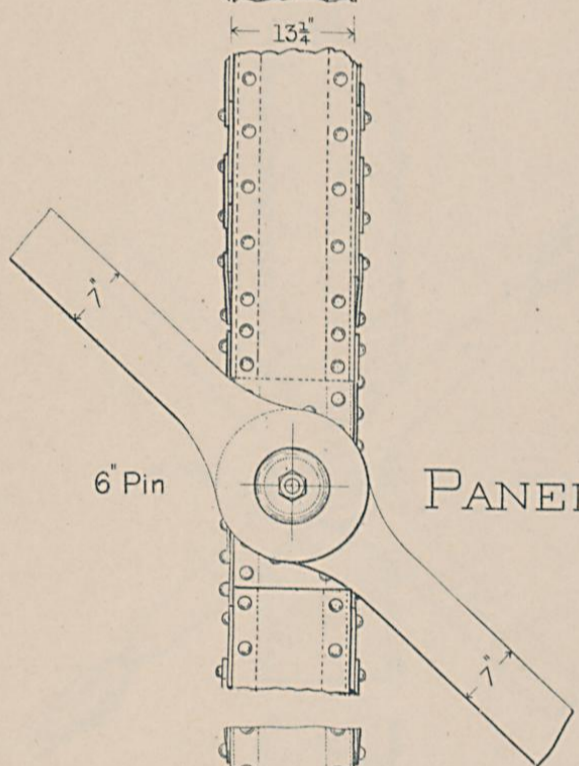
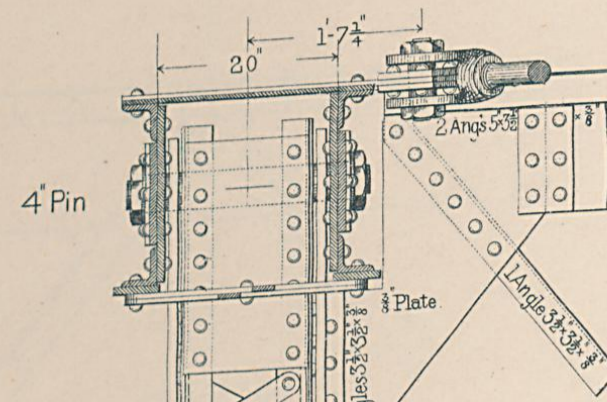
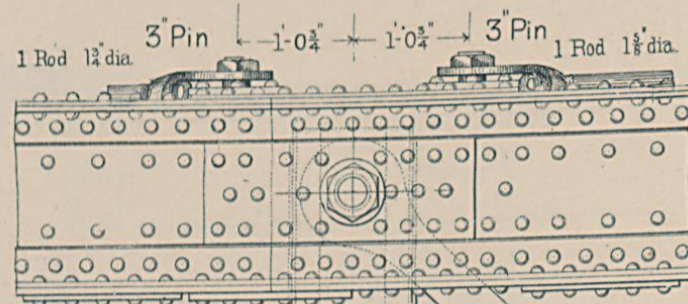
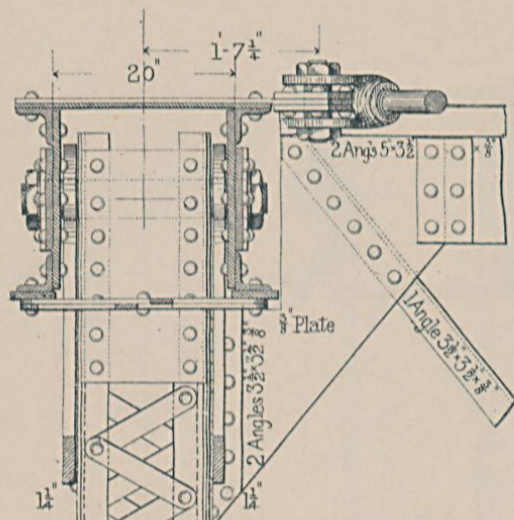
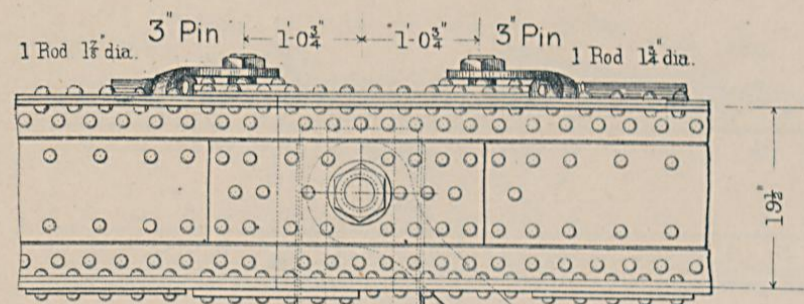

PANEL POINT 5

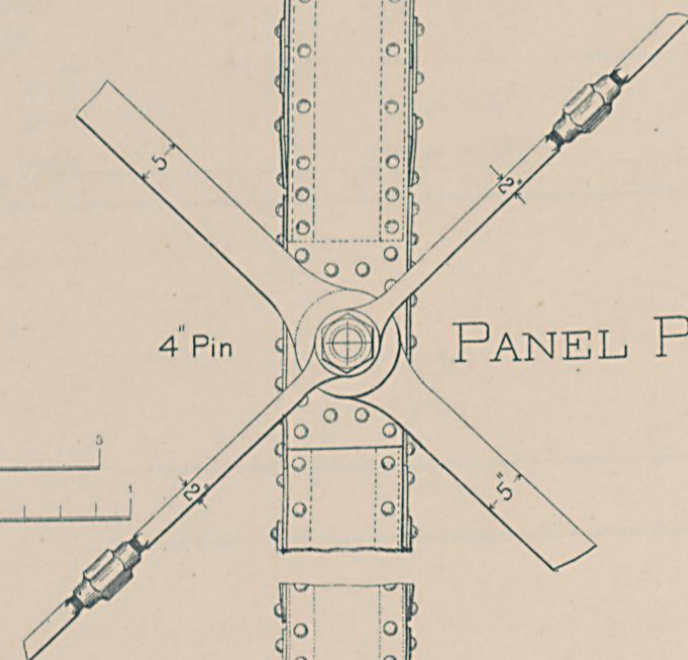
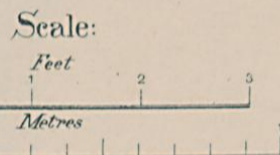
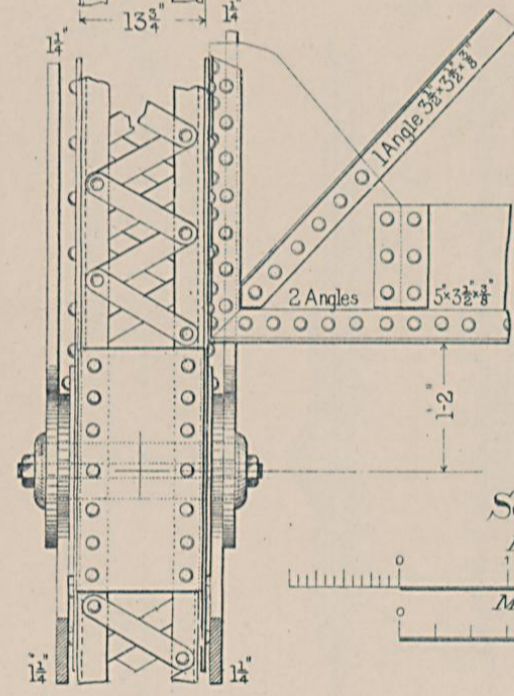

PANEL POINT 6

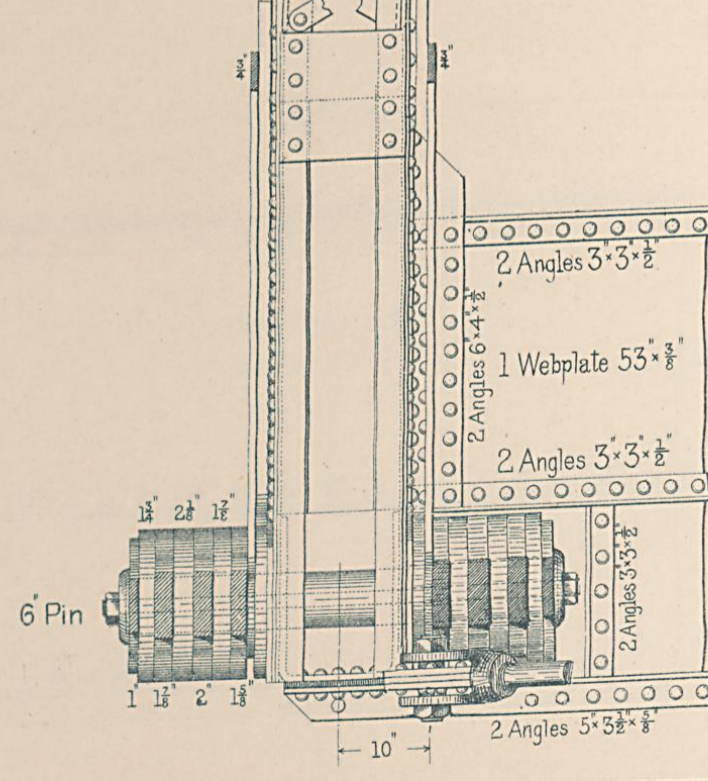
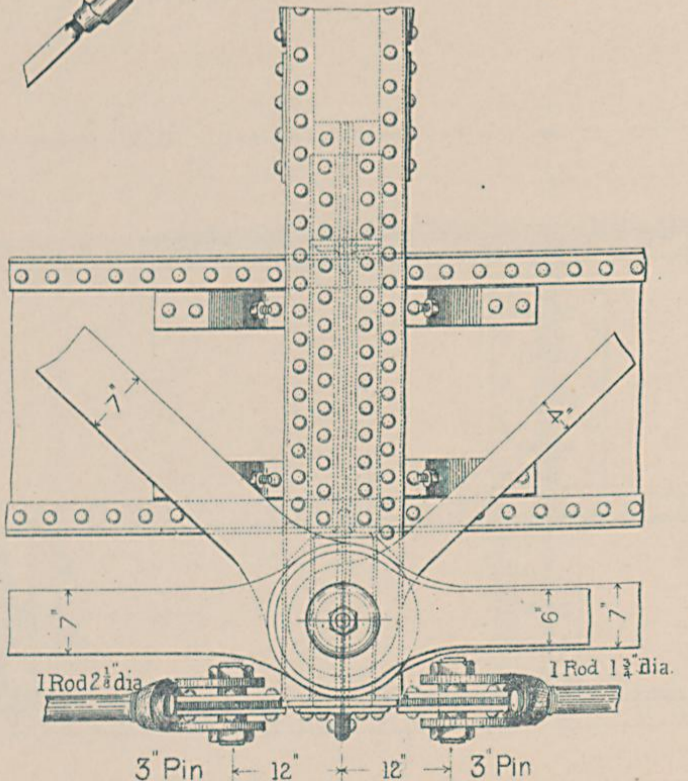
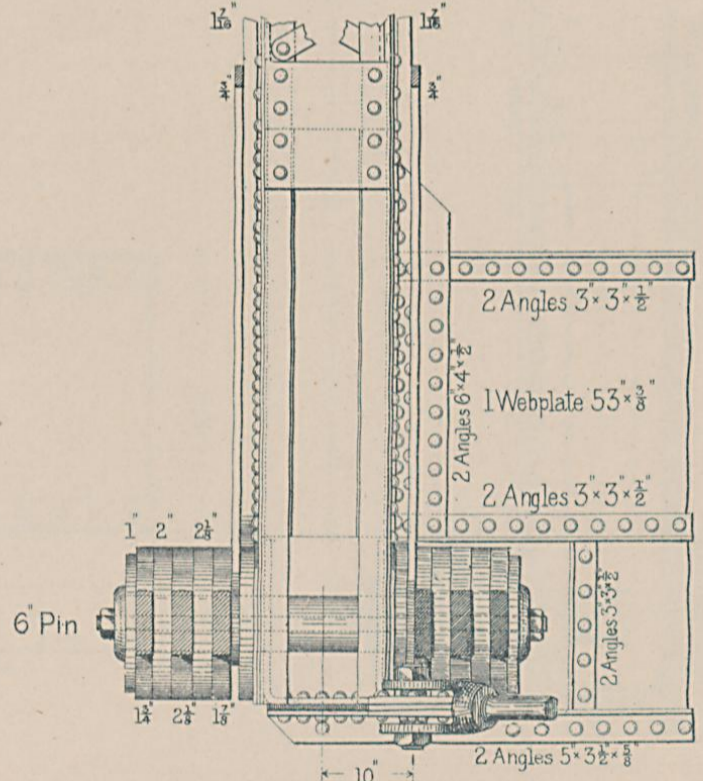
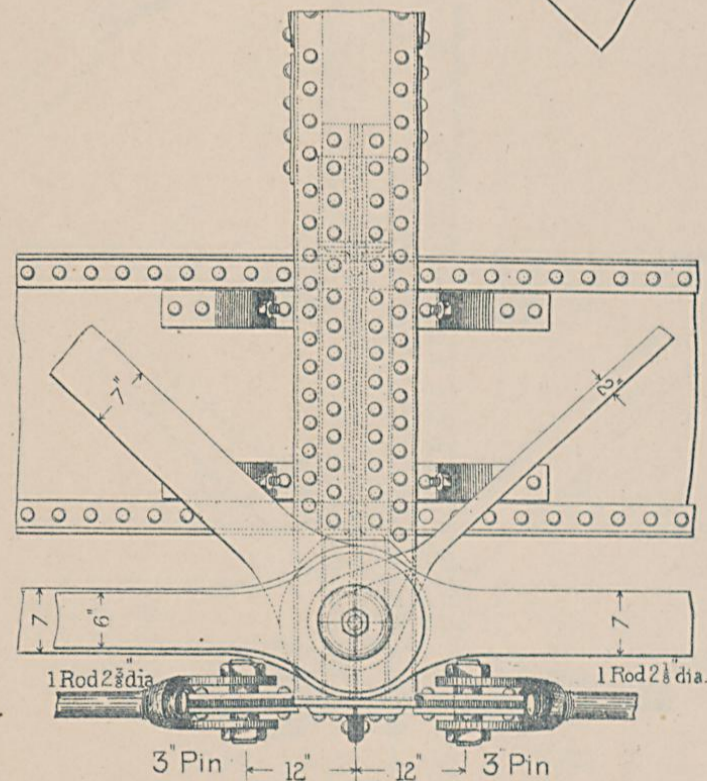
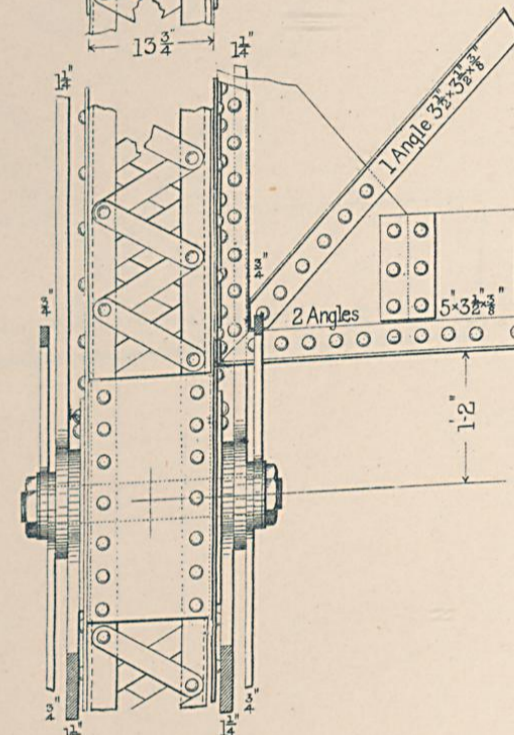

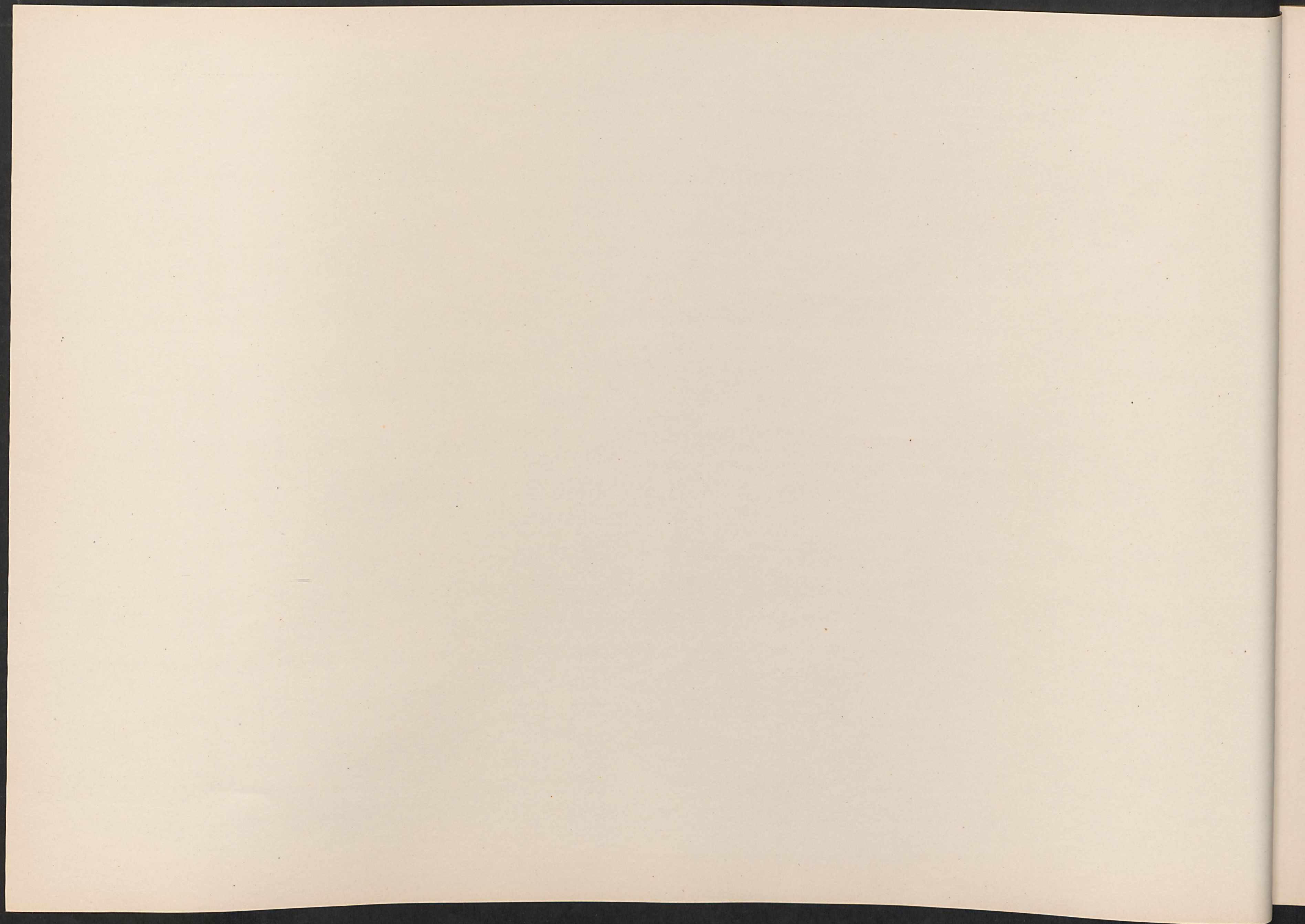

C. B. & Q. R. R.

# NEBRASKA CITY BRIDGE THROUGH SPAN 400<sup>FT</sup> 0<sup>IN</sup> C. TO C. END PINS.

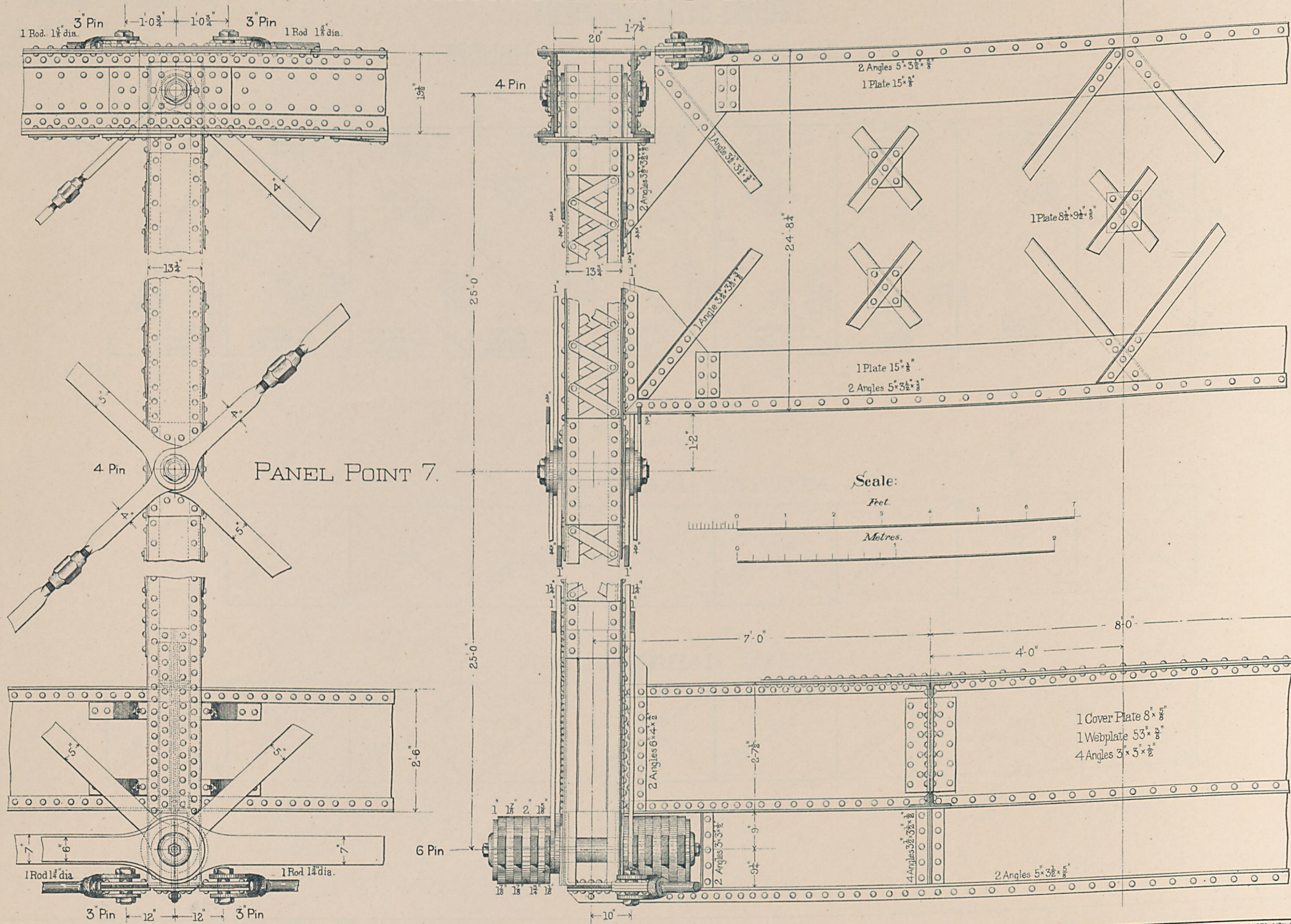

Scale:



ROBERT A. WELCKE PHOTO LITH. 176 WILLIAM ST. N.Y.

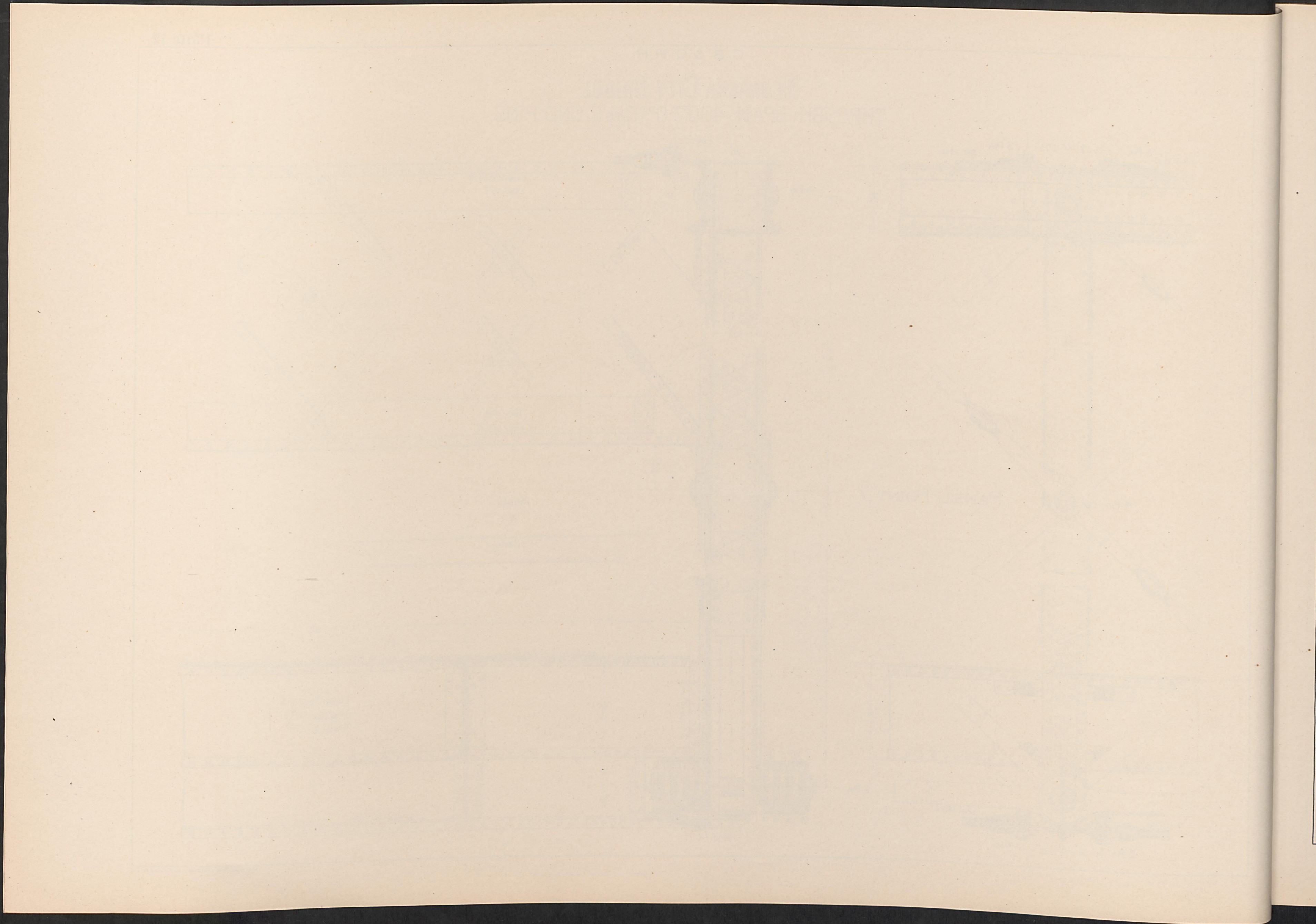

Assumed Loads  
 D.L. 3200 lbs. pr. ft. of Bridge.  
 L.L. 3000 " " " " " "  
 E.L. 5000 " " " " " "

C.B. & Q.R.R.  
**NEBRASKA CITY BRIDGE**  
 THROUGH SPAN 400 FT 0 IN C. TO C. END PINS.

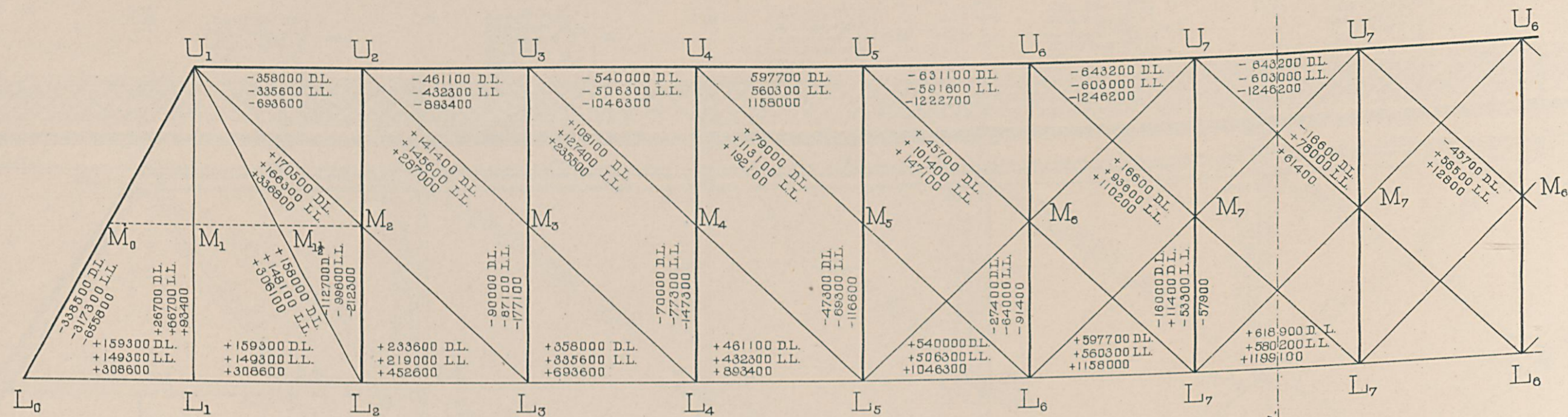

TOP LATERAL SYSTEM

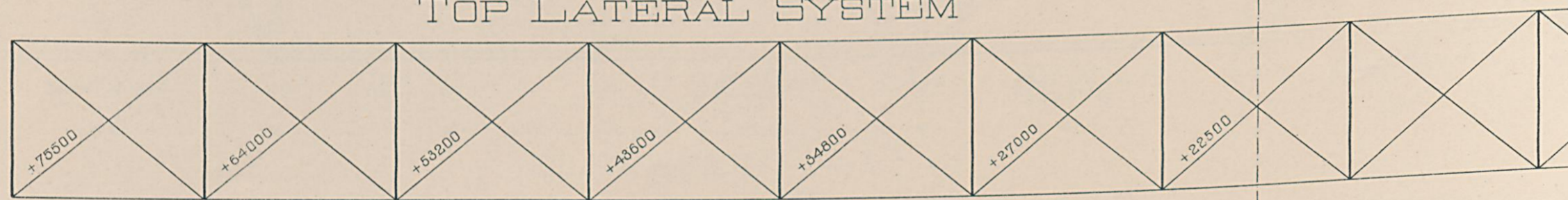

BOTTOM LATERAL SYSTEM

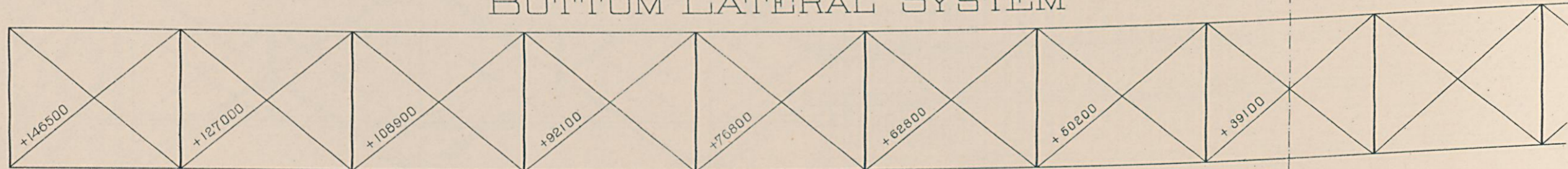

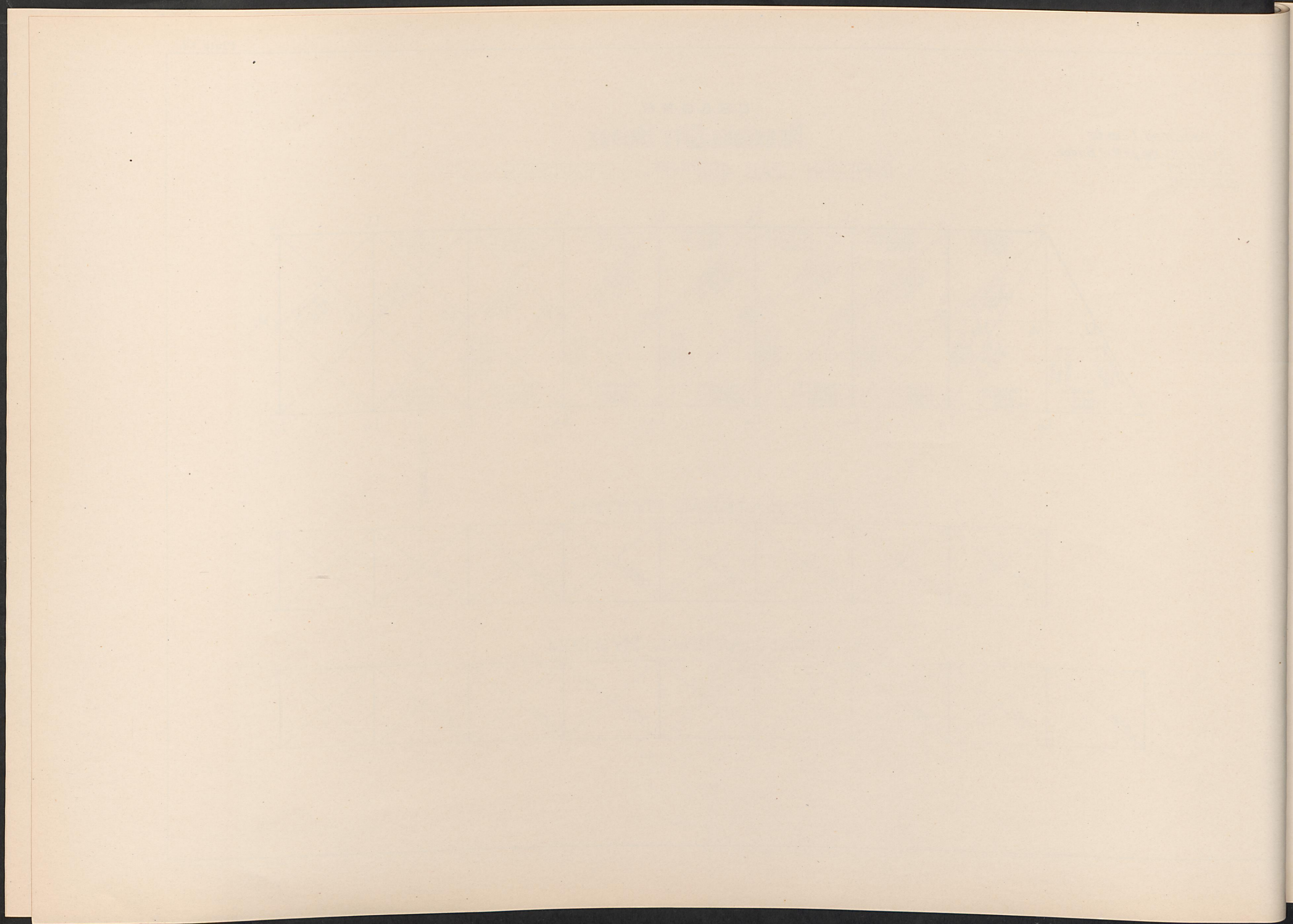

C. B. & Q. R. R.  
NEBRASKA CITY BRIDGE  
DECK SPAN 325 FT 0 IN C. TO C. END PINS.

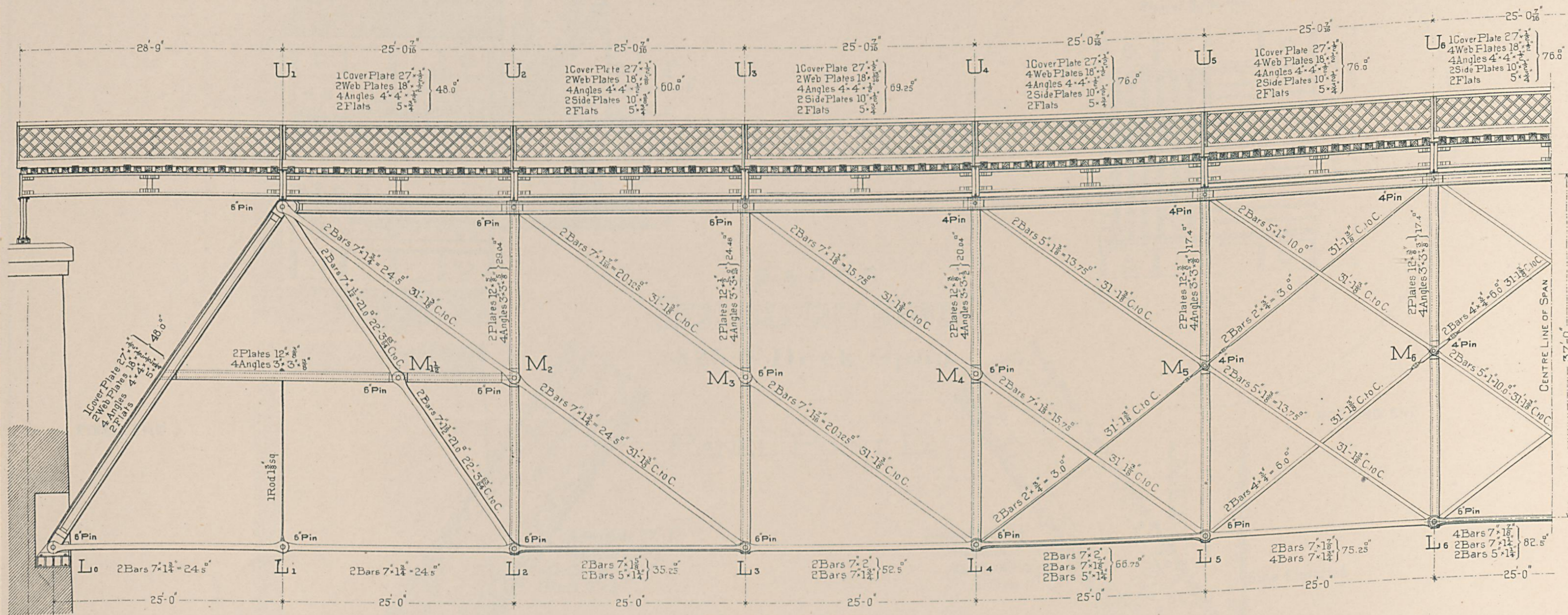

ELEVATION

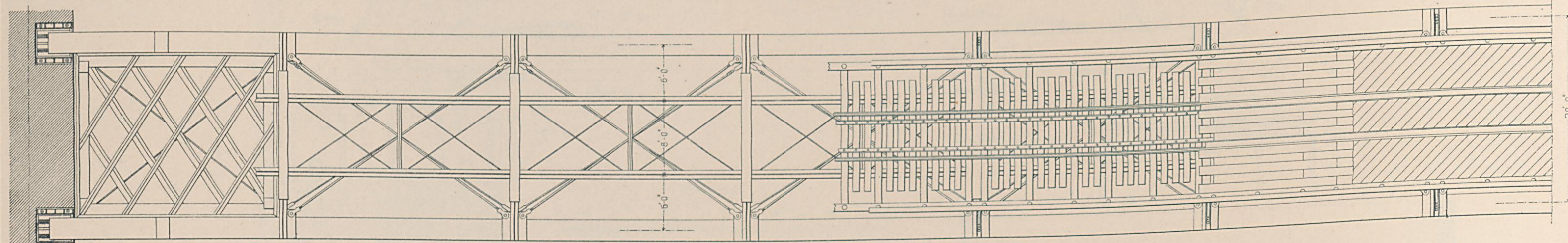

PLAN

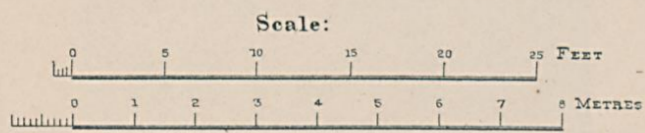

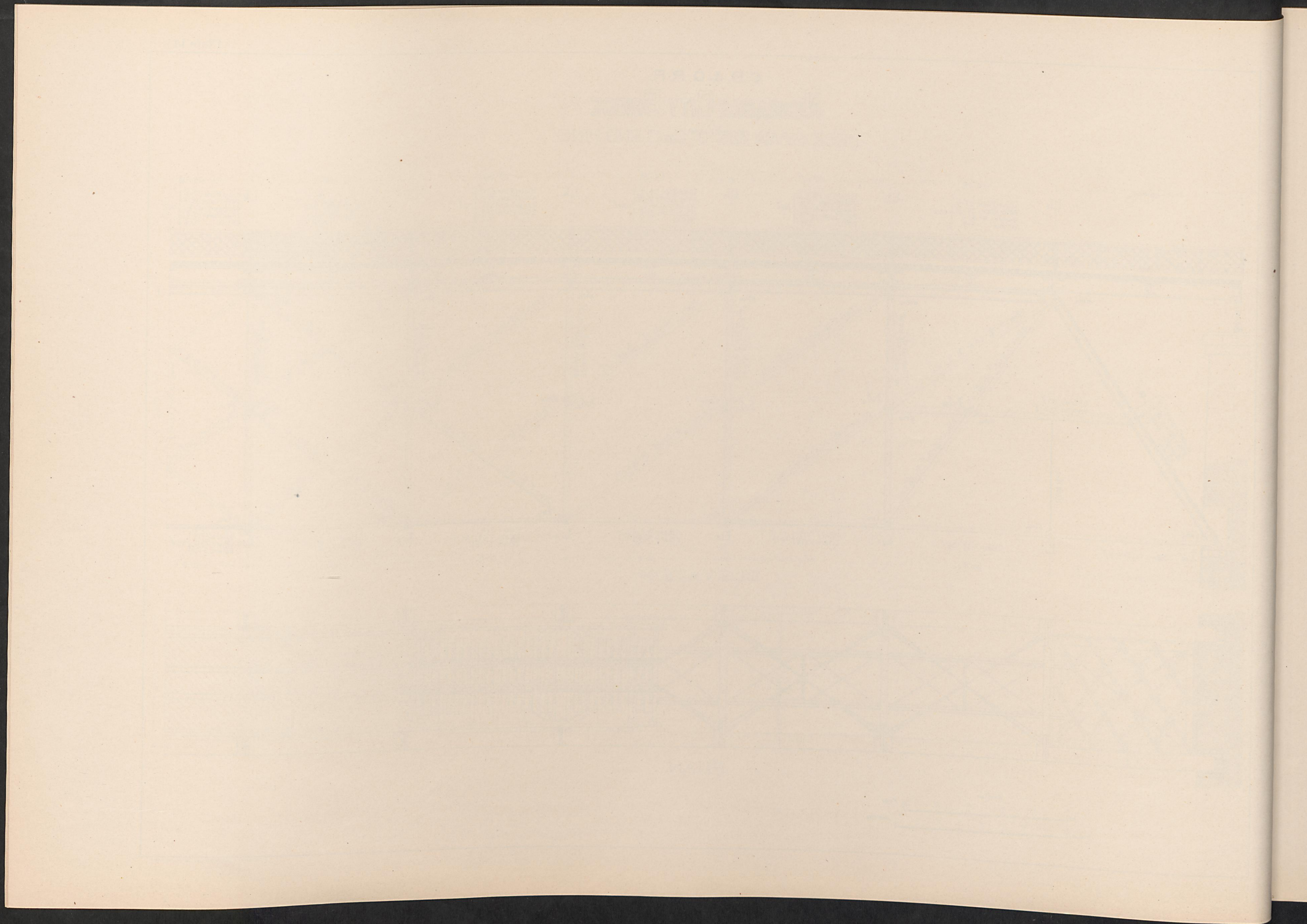

Plan

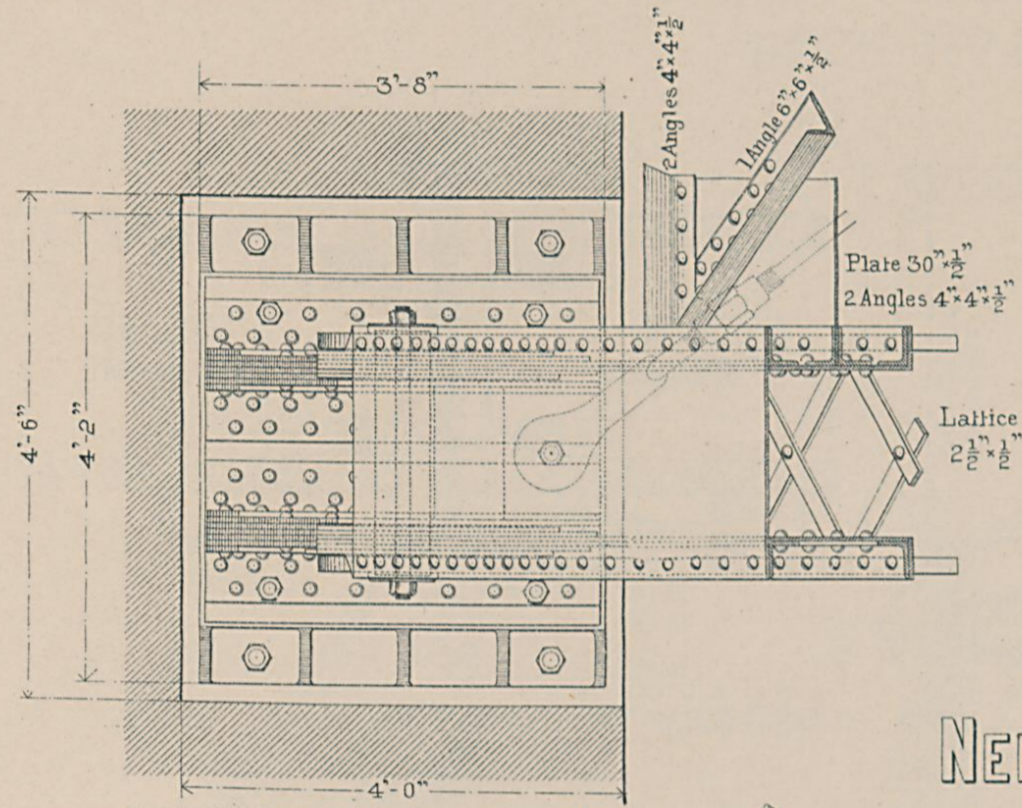

Plan of Boiler Nest

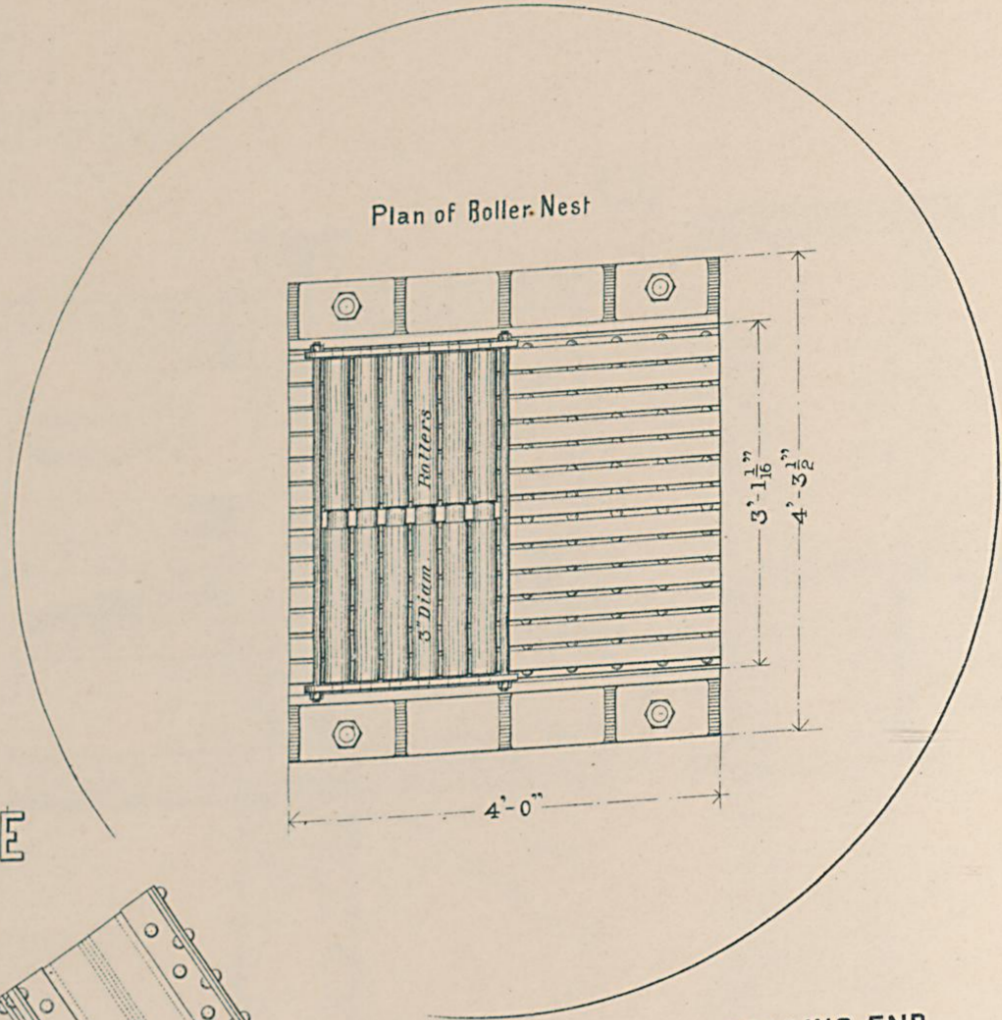

C. B. & Q. R. R.  
**NEBRASKA CITY BRIDGE**  
 325'-0" Deck Span

PANEL POINT L.

FIXED END

Side Elevation

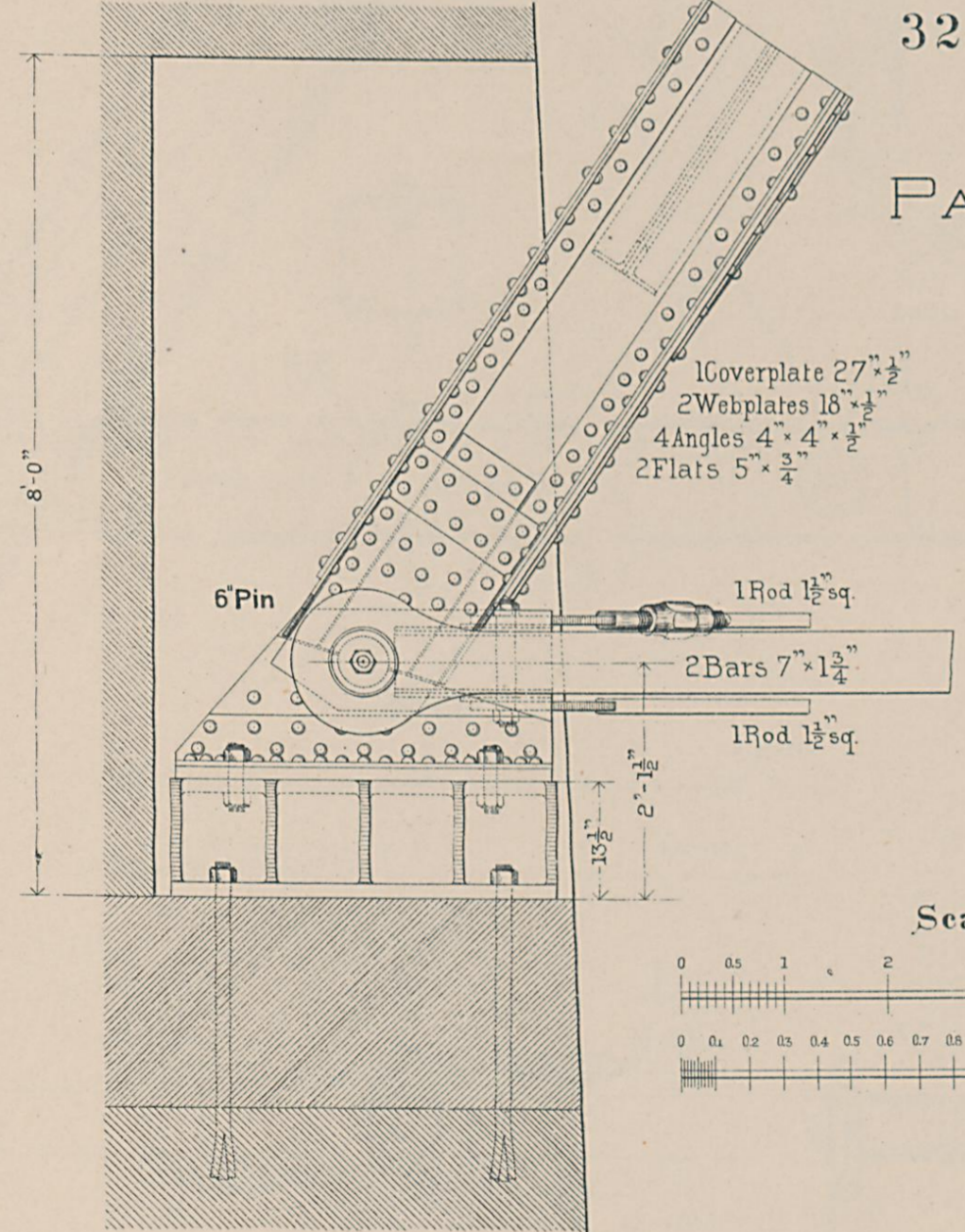

ROLLING END

Side Elevation

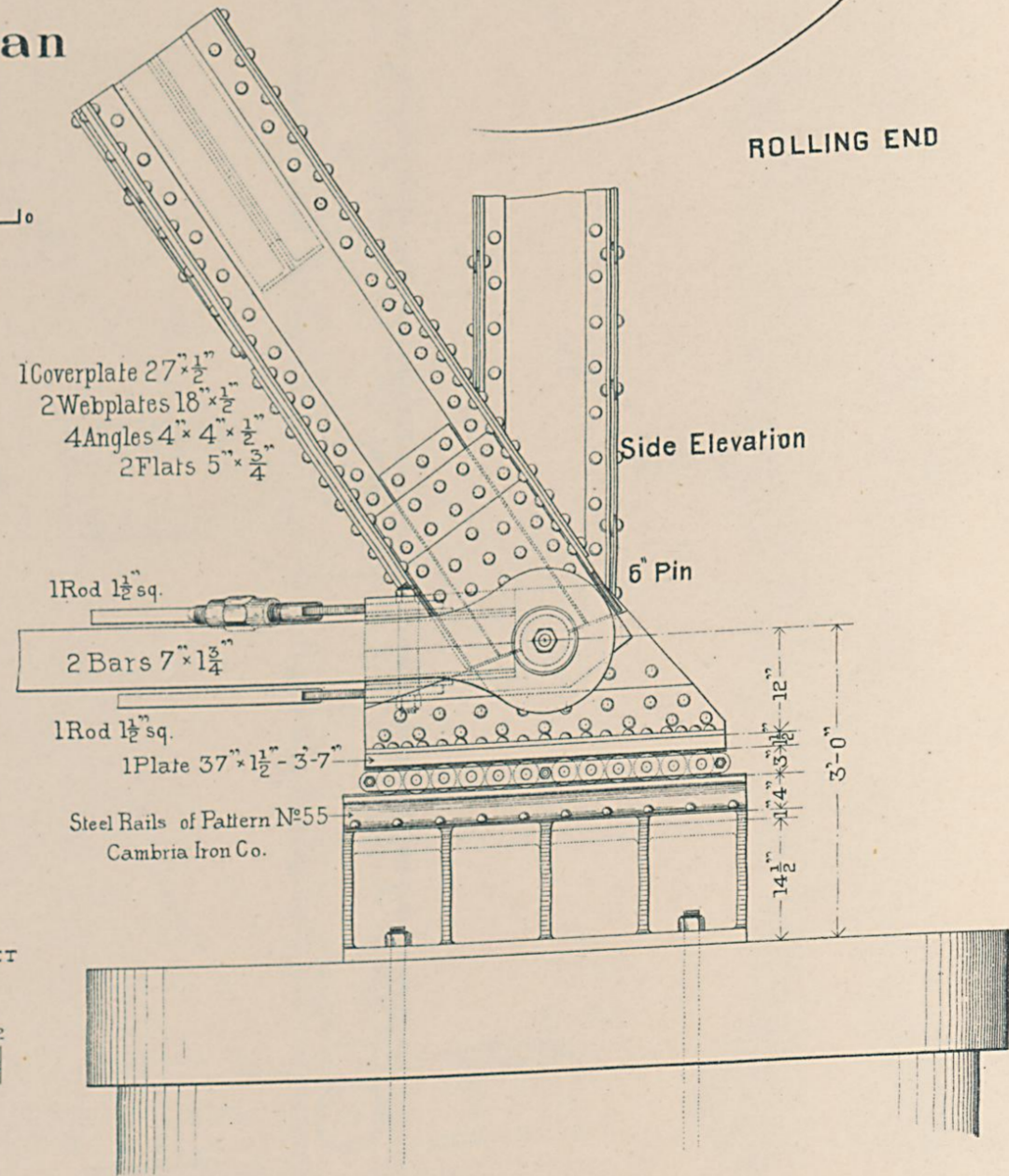

Scales:

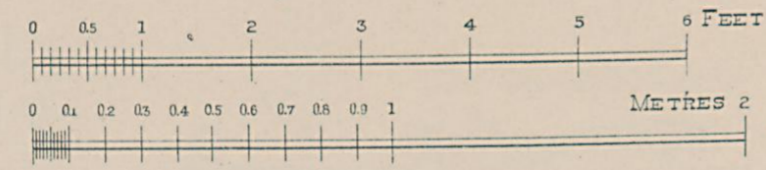

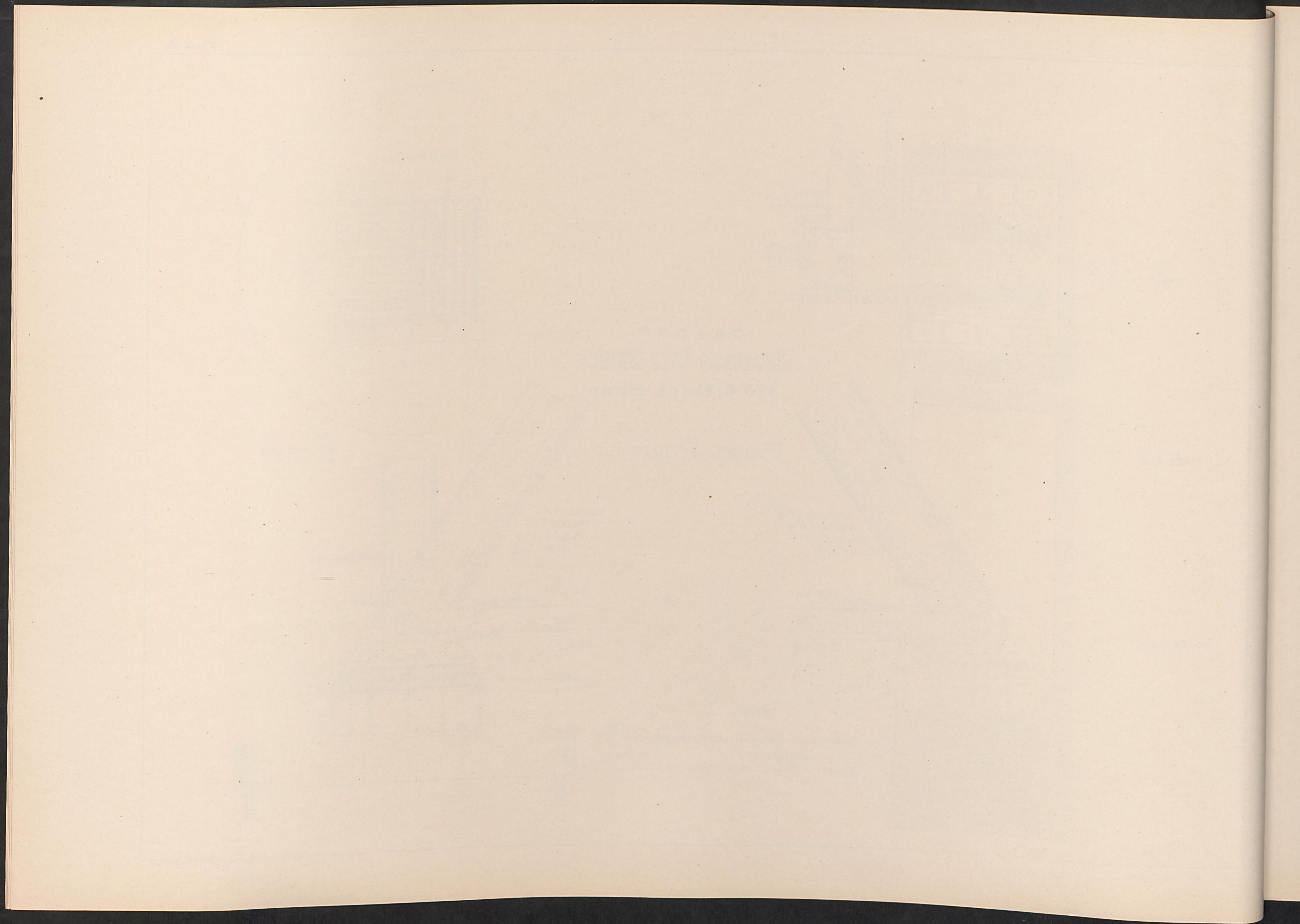

C. B. & Q. R. R.  
**NEBRASKA CITY BRIDGE**  
 DECK SPAN - 325 FT 0 IN C. TO C. END PINS

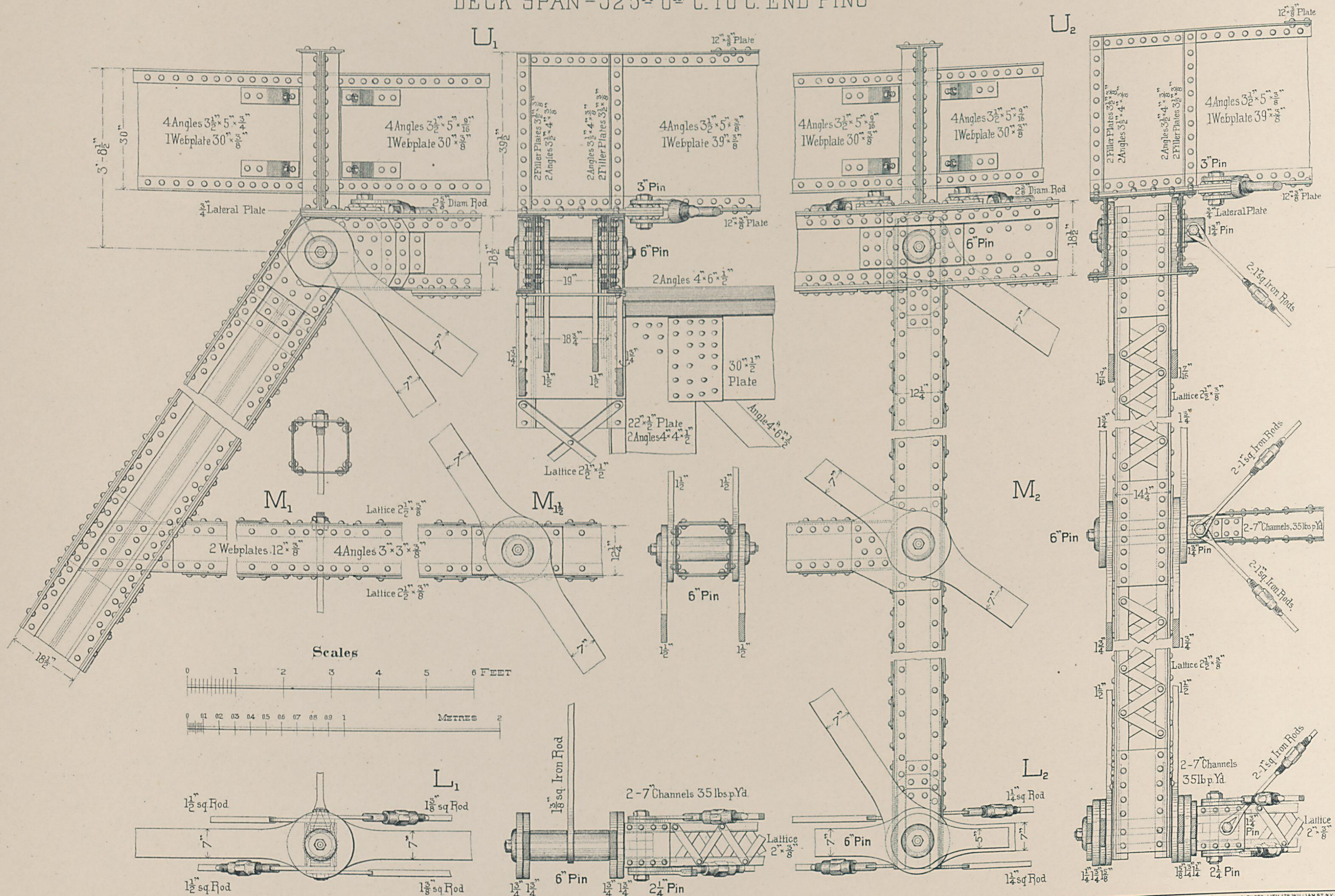

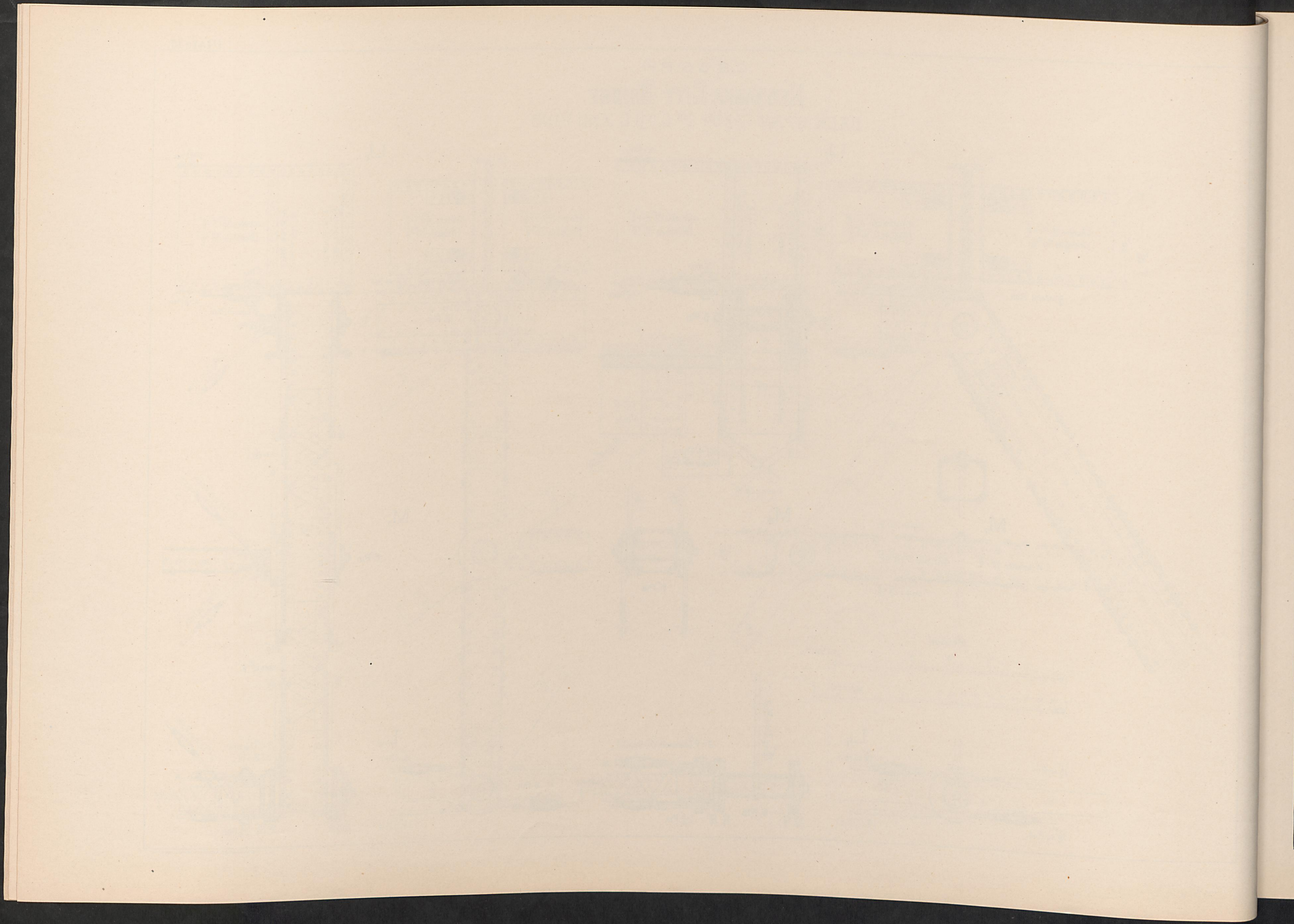

C.B. & Q.R.R.  
**NEBRASKA CITY BRIDGE**  
DECK SPAN 325 FT 0 IN C. TO C. END PINS

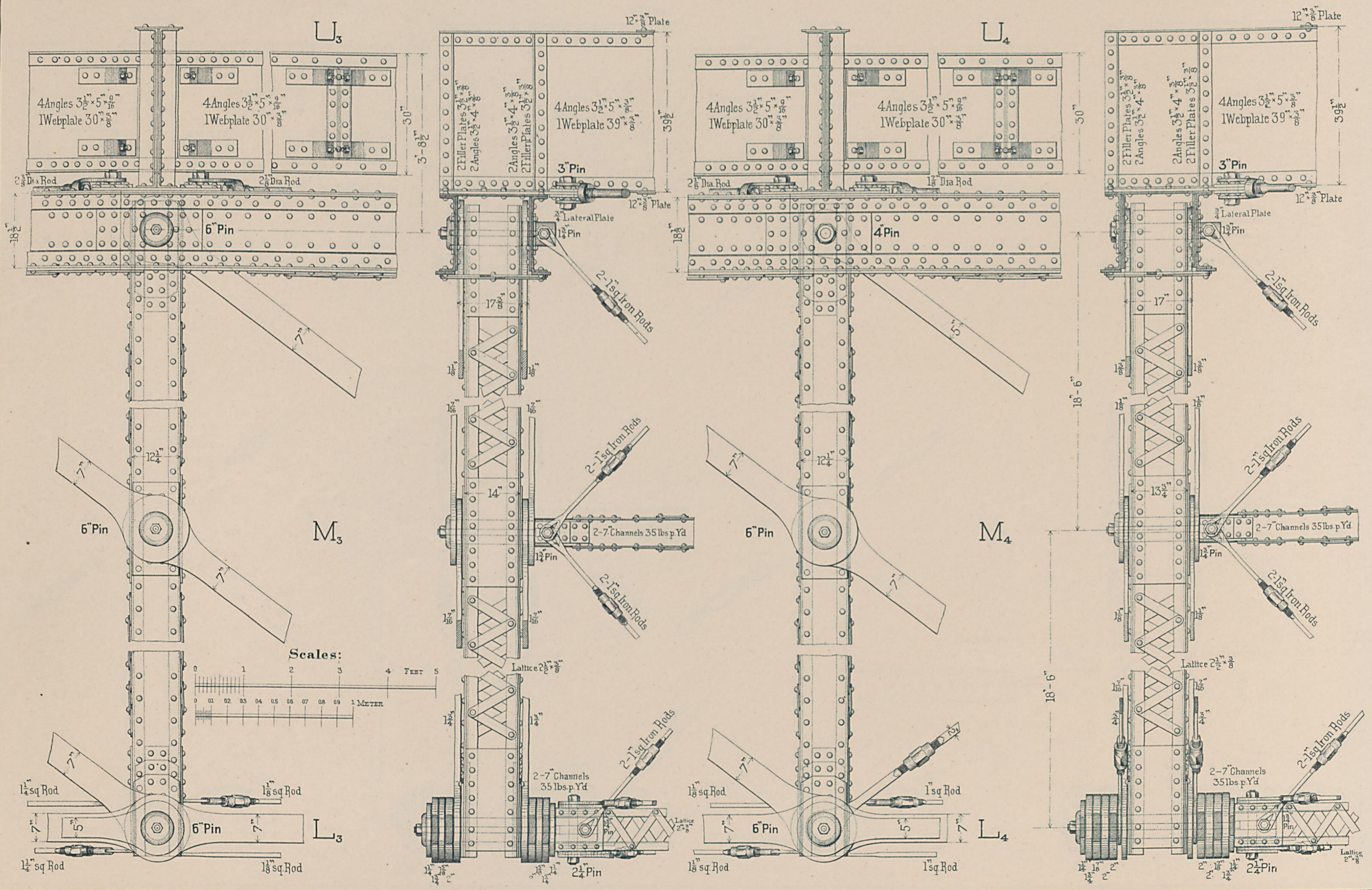

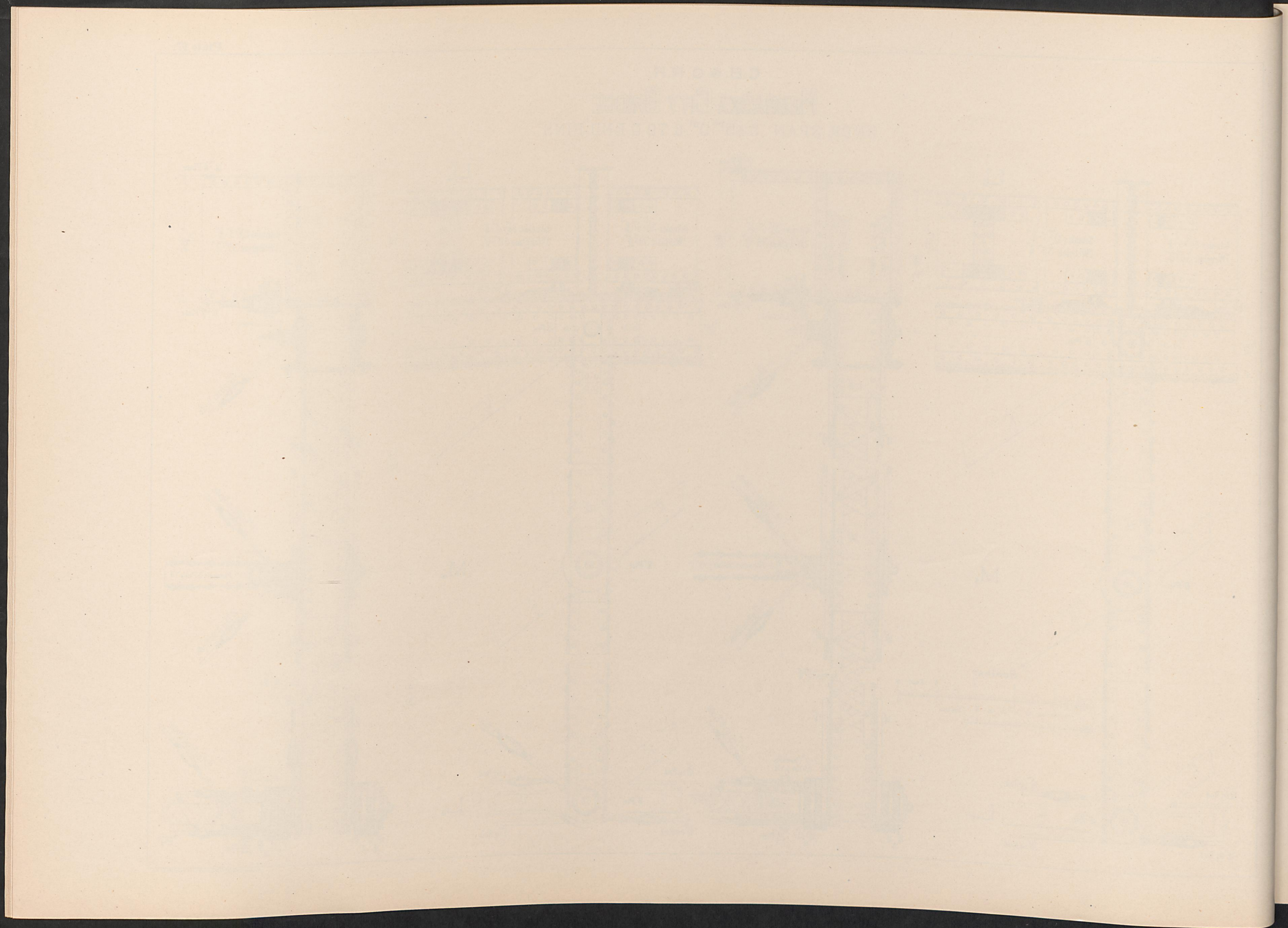

C.B. & Q.R.R.  
NEBRASKA CITY BRIDGE  
DECK SPAN 325<sup>FT</sup> 0<sup>IN</sup> C TO C END PINS

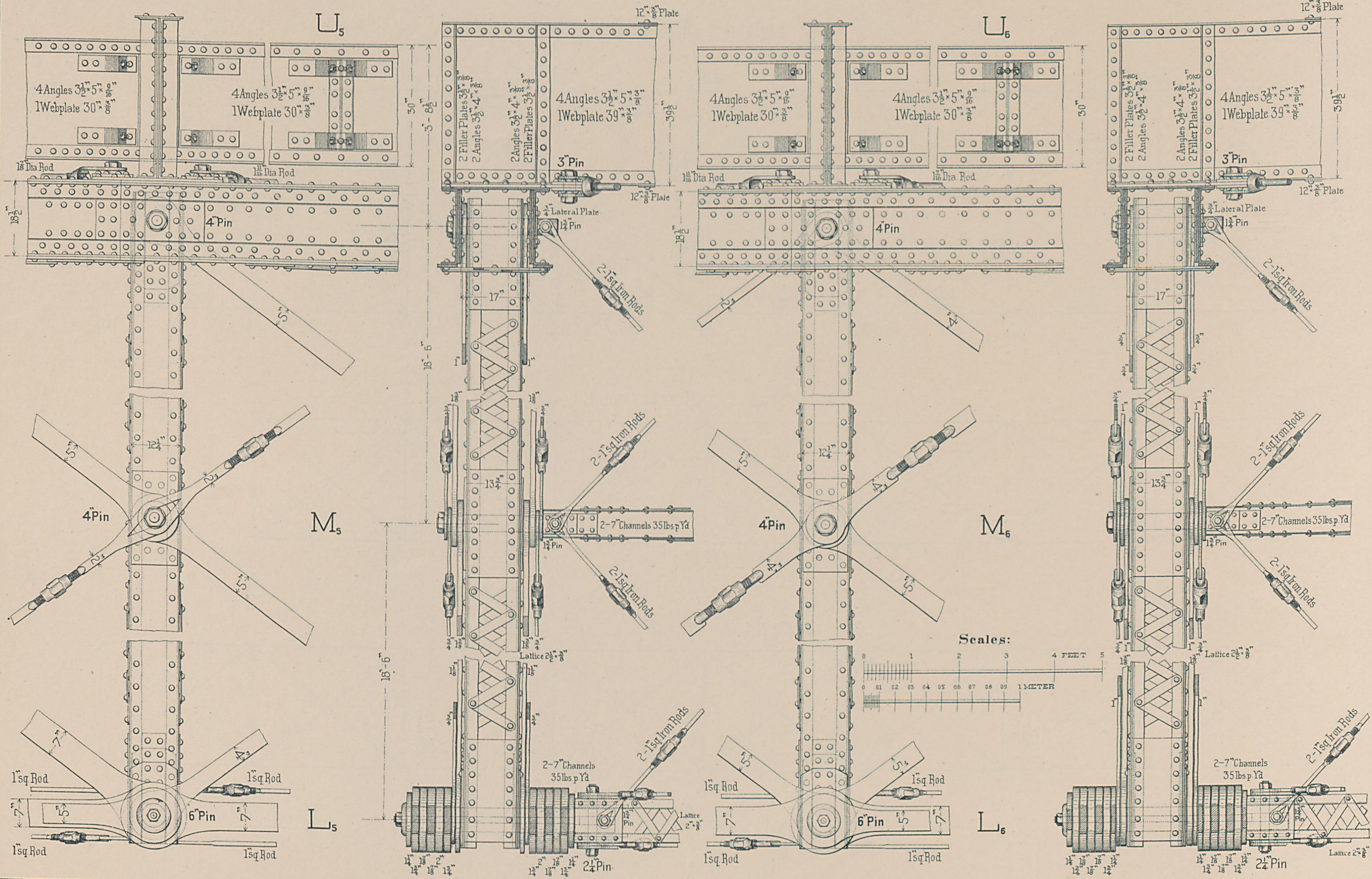

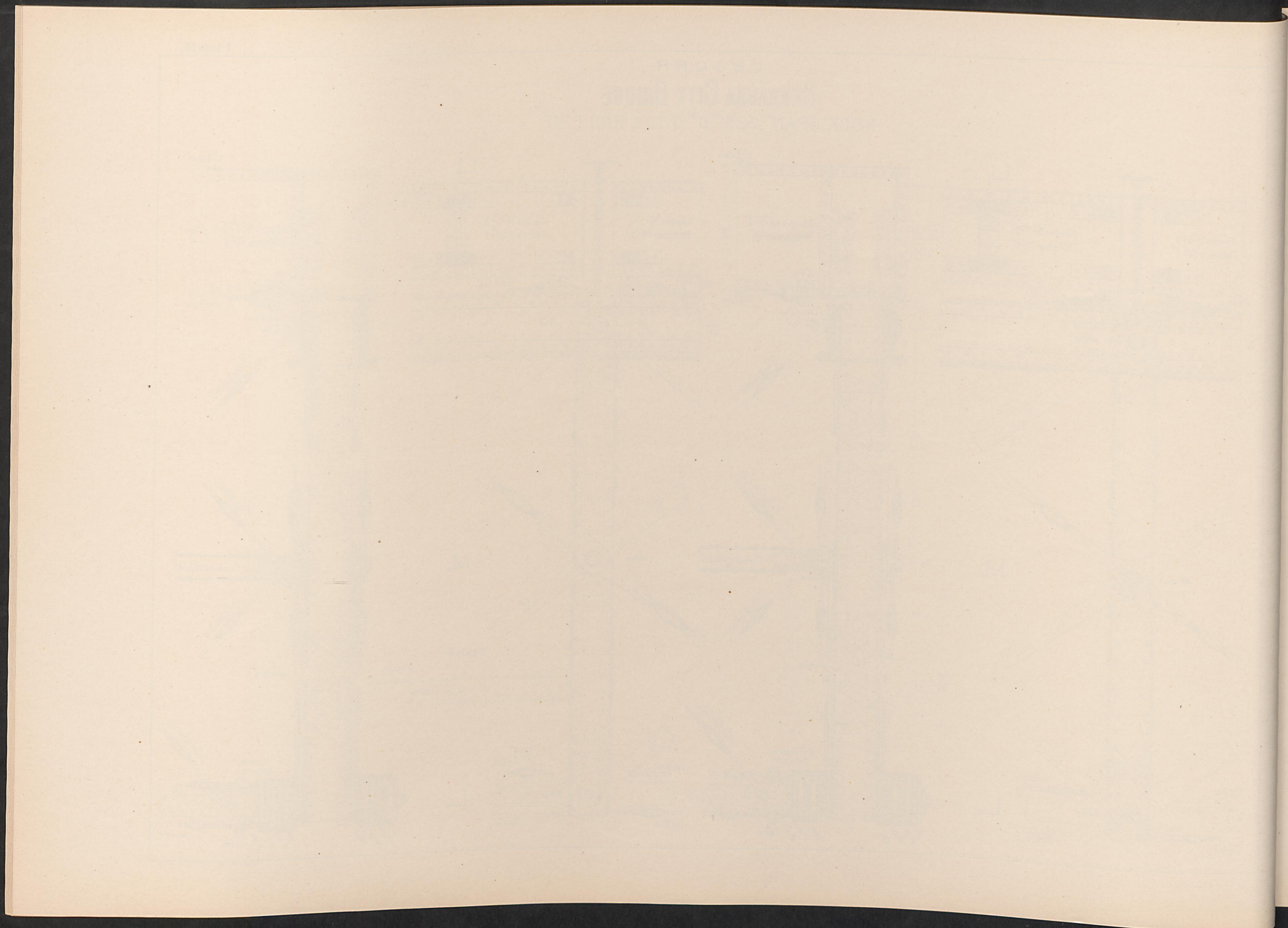

C. B. & Q. R. R.  
**NEBRASKA CITY BRIDGE**  
DECK SPAN - 325<sup>FT</sup> 0<sup>IN</sup> C. TO C. END PINS  
STRAIN SHEET

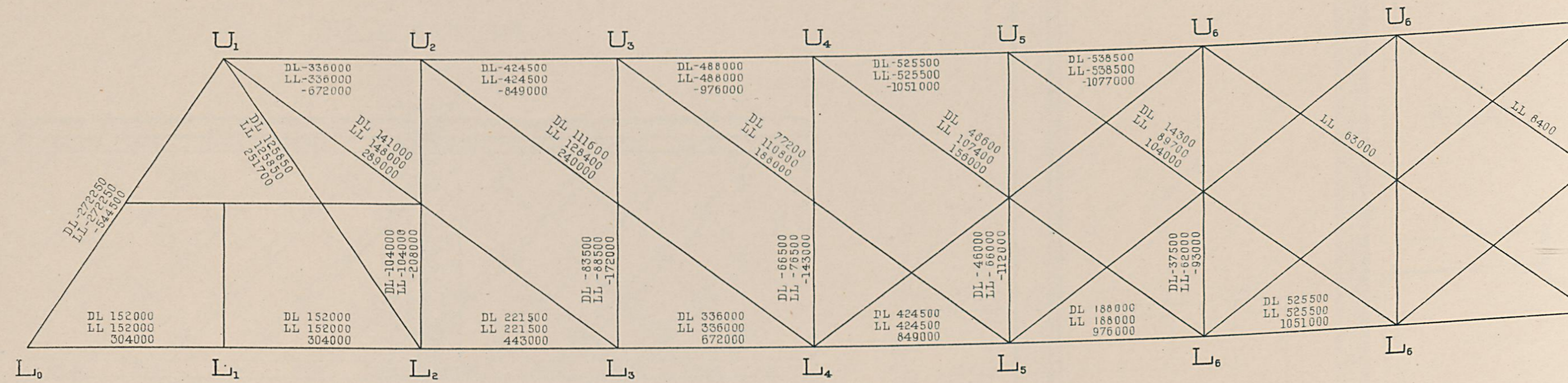

TOP LATERAL SYSTEM

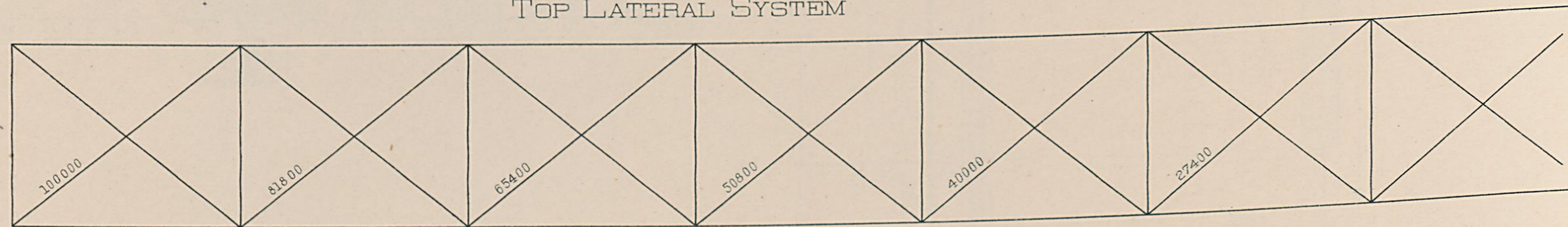

BOTTOM LATERAL SYSTEM

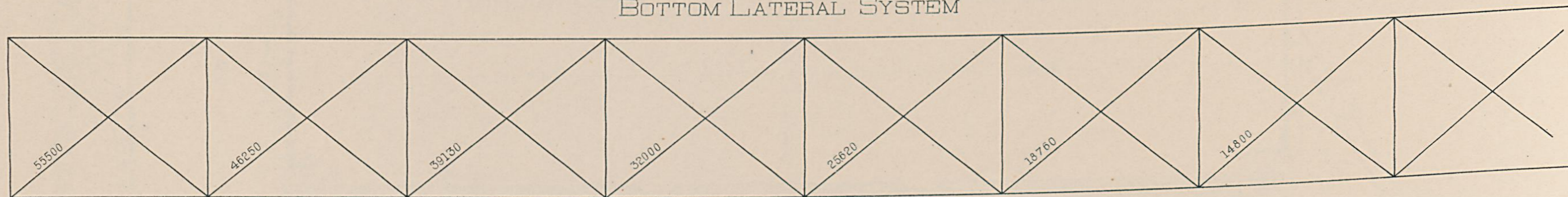

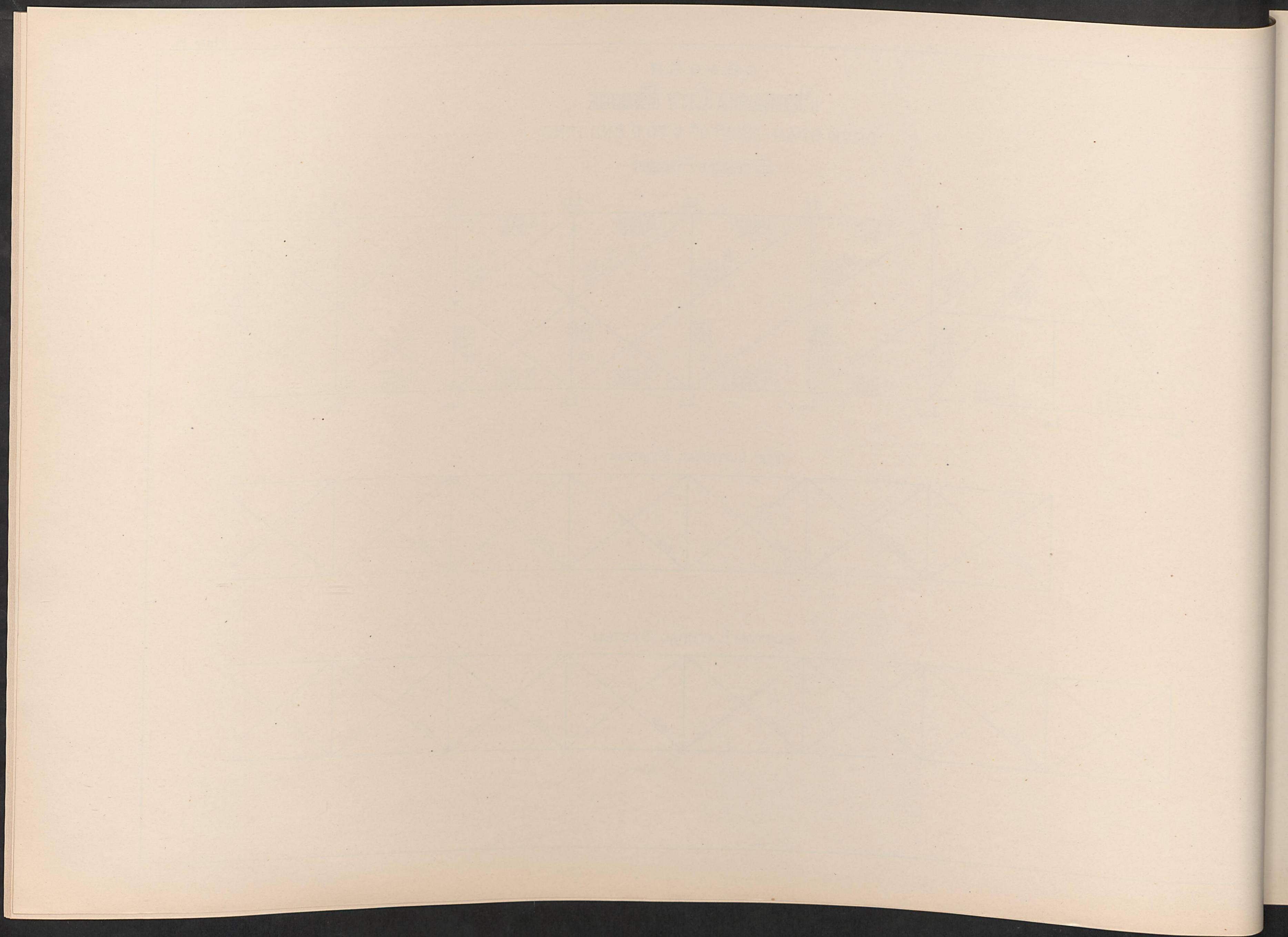

# C. B. & Q. R. R. NEBRASKA CITY BRIDGE FLOOR

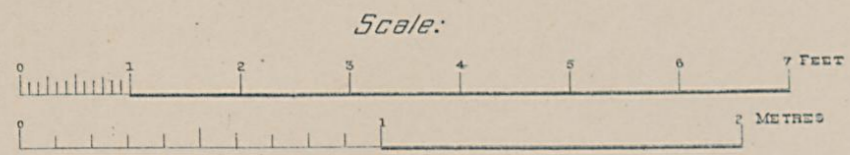

### ELEVATION

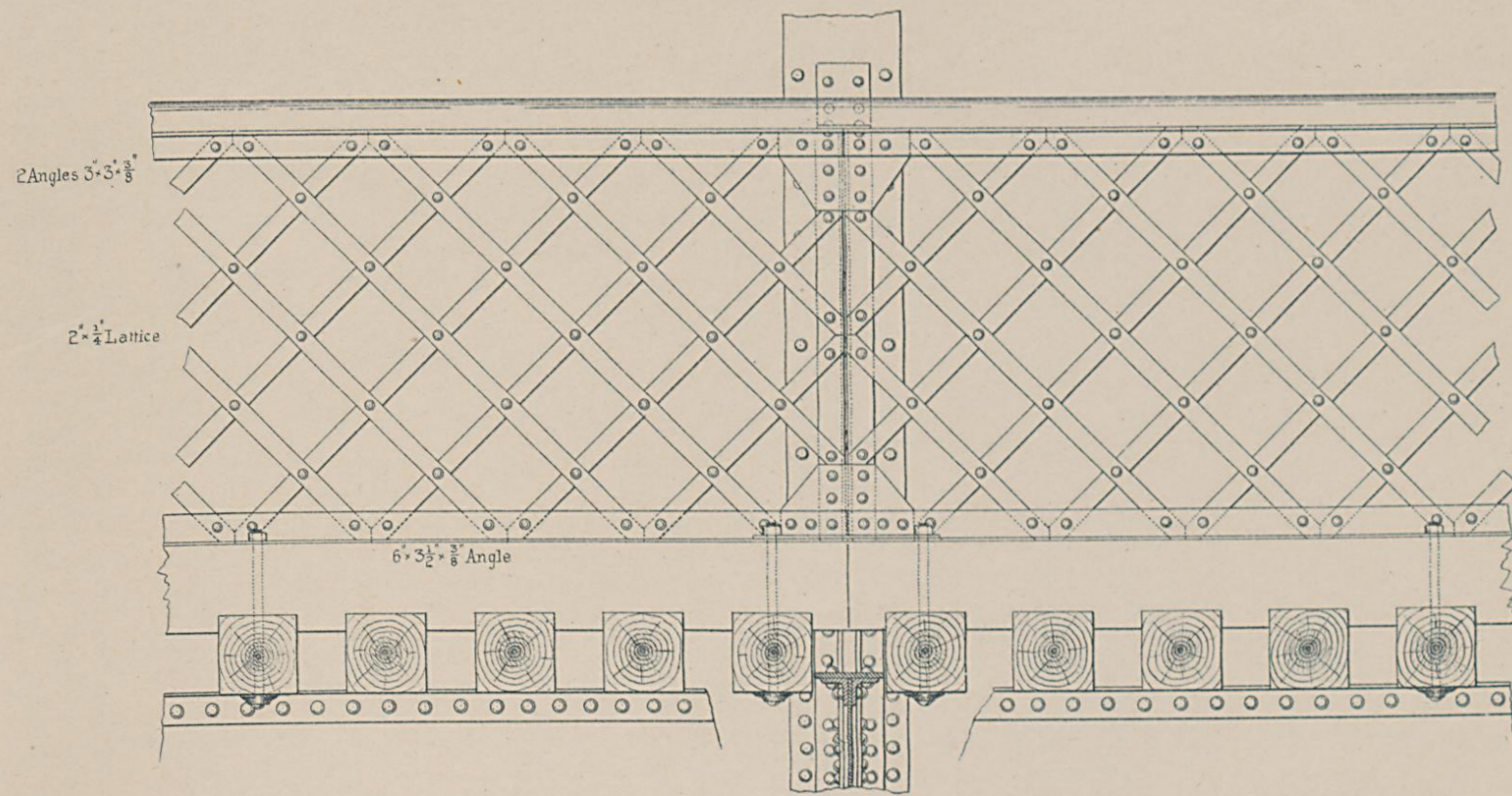

### PLAN

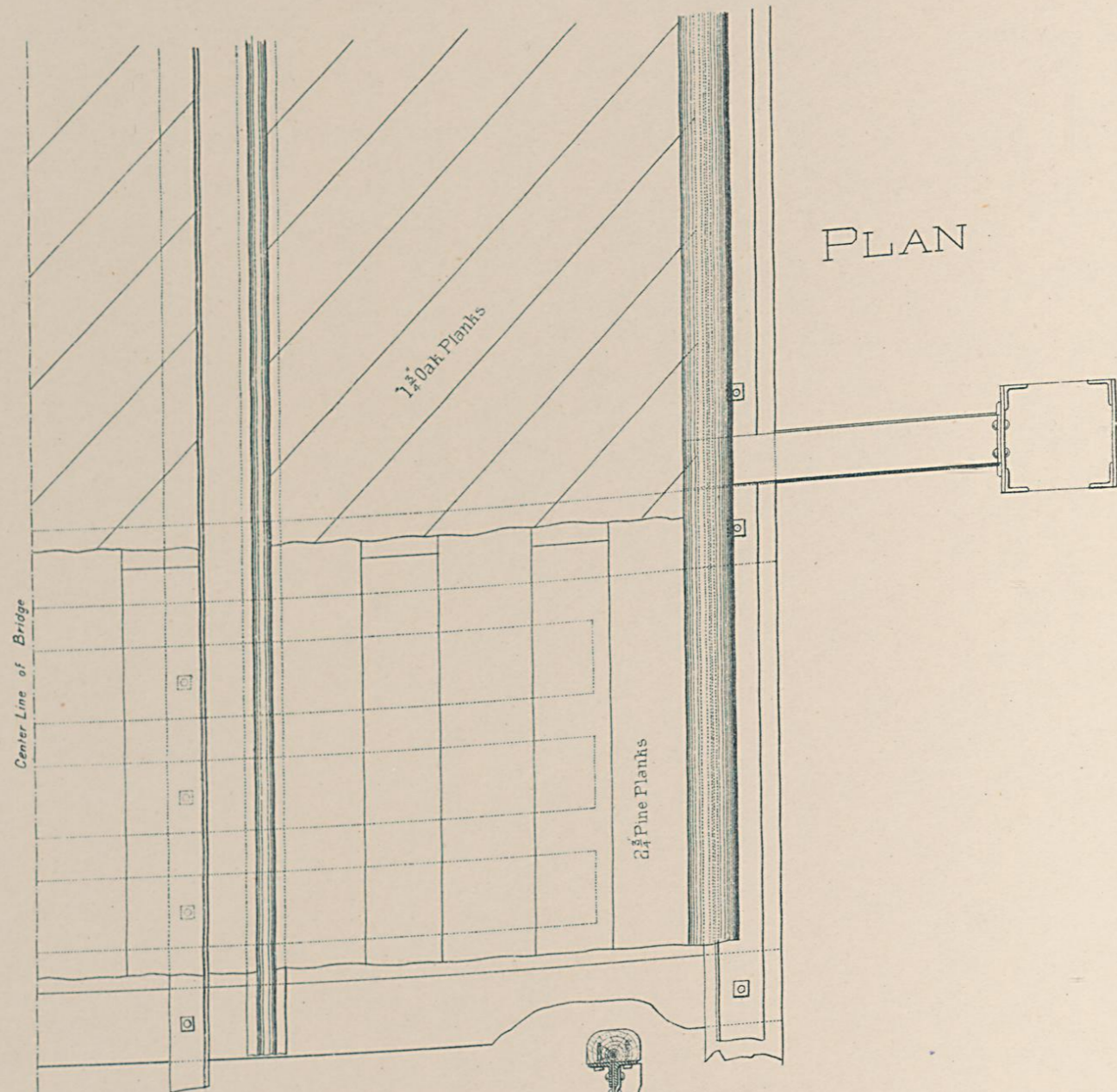

### SECTION

